



GROUNDING LOW VOLTAGE (GLV) USER MANUAL

Abstract

This document describes user manual for the GLV system.

May 6, 2018

Introduction

This document presents the basic usage of the GLV system for the LFEV-2018 project. This year's GLV didn't have major changes besides deleting extra ports on the side panels as well as integrating with the new VSCADA system. The whole new GLV enclosure is redesigned therefore the GLV is rewired in the new box. (See wiring diagram)

Charging the Battery

The GLV Battery must be charged for proper operation of the GLV system. The GLV battery can be charged using a PST-G100-24F8 charger. This charger charges the 24V battery at 1.5A, and it includes a plug and forget algorithm which allows it to be plugged in without the possibility of overcharging the battery. The charger has lights which indicate when the battery has finished charging. The fully charged battery can be used for approximately 6 hours.

Break Out Board

This year the GLV is using the same PCB as the last year.

To find more information. Please visit <https://sites.lafayette.edu/ece492-sp17/subsystems/glv/>

Safety System OK lamp (SSOK)

To comply with the rule this year, a pair of SSOK lamps are added. It was added on the pin MSREST_ B on the PCB board in order to achieve its functionality.

VSCADA Interaction

This year the GLV interact with the VSCADA differently. This year's VSCADA uses a PI-CAN shield that allows the Raspberry Pi plug in the DB-9 directly. The VSCADA is still powered by the GLV as well as the GLV debug screen. It is a more direct approach and it allows the GLV to power the VSCADA through its DC/DC convertor.

Safety Loop Diagram

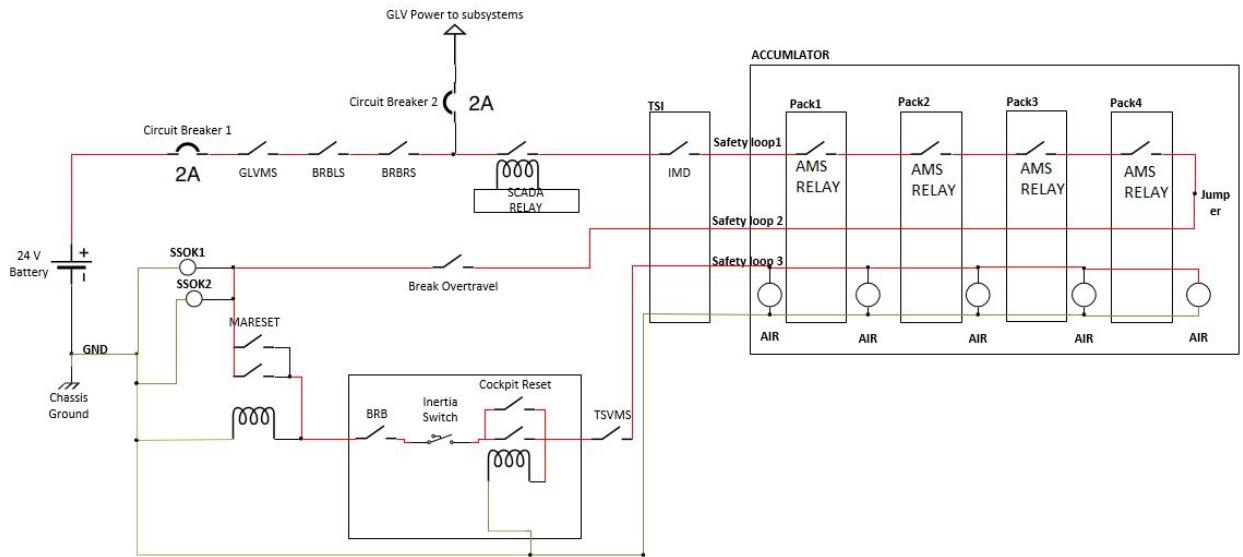

The safety loop is on when all of the switches/relays/buttons are closed and power can get to the airs to close them. If you are having trouble closing the loop then start at the beginning of the loop and go step by step until the light turns off. This indicates where the loop has a problem. If you are having trouble closing the airs make sure the glv battery has enough energy or that the sloop is actually fully closed.

GLV Enclosure

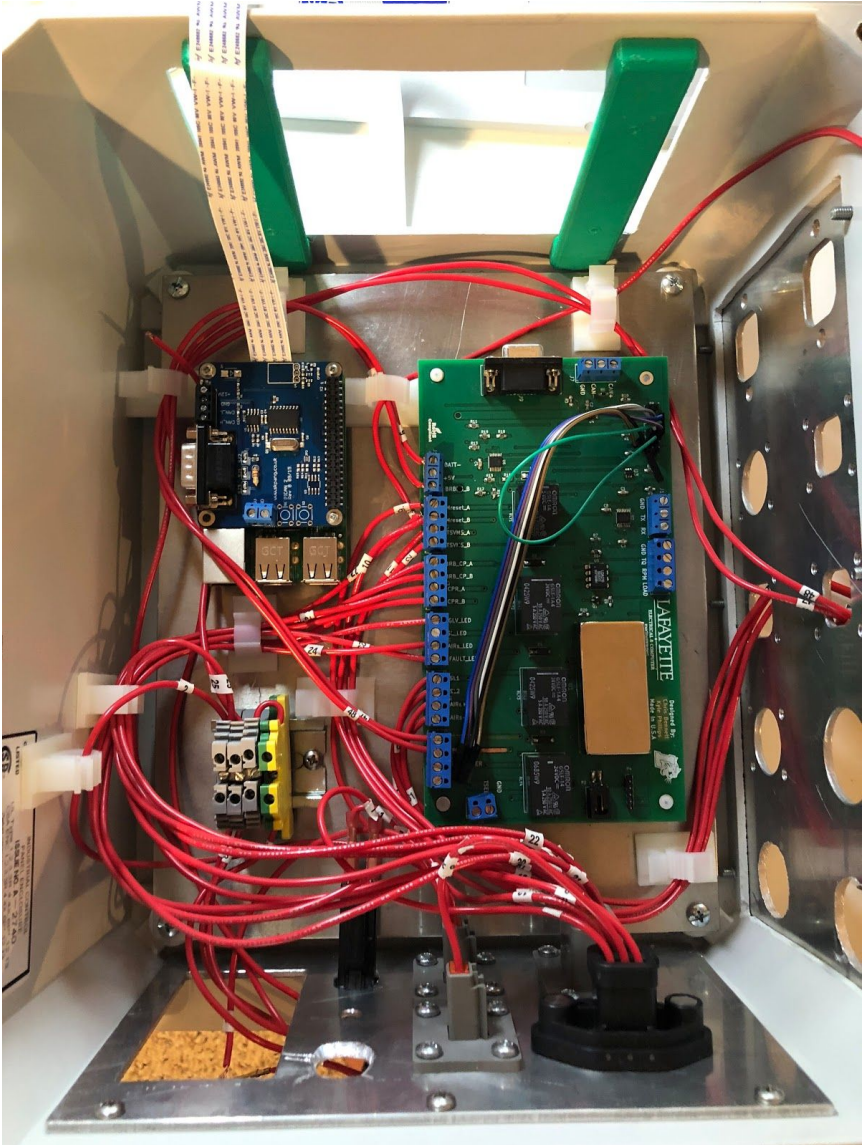

GLV Wiring Diagram

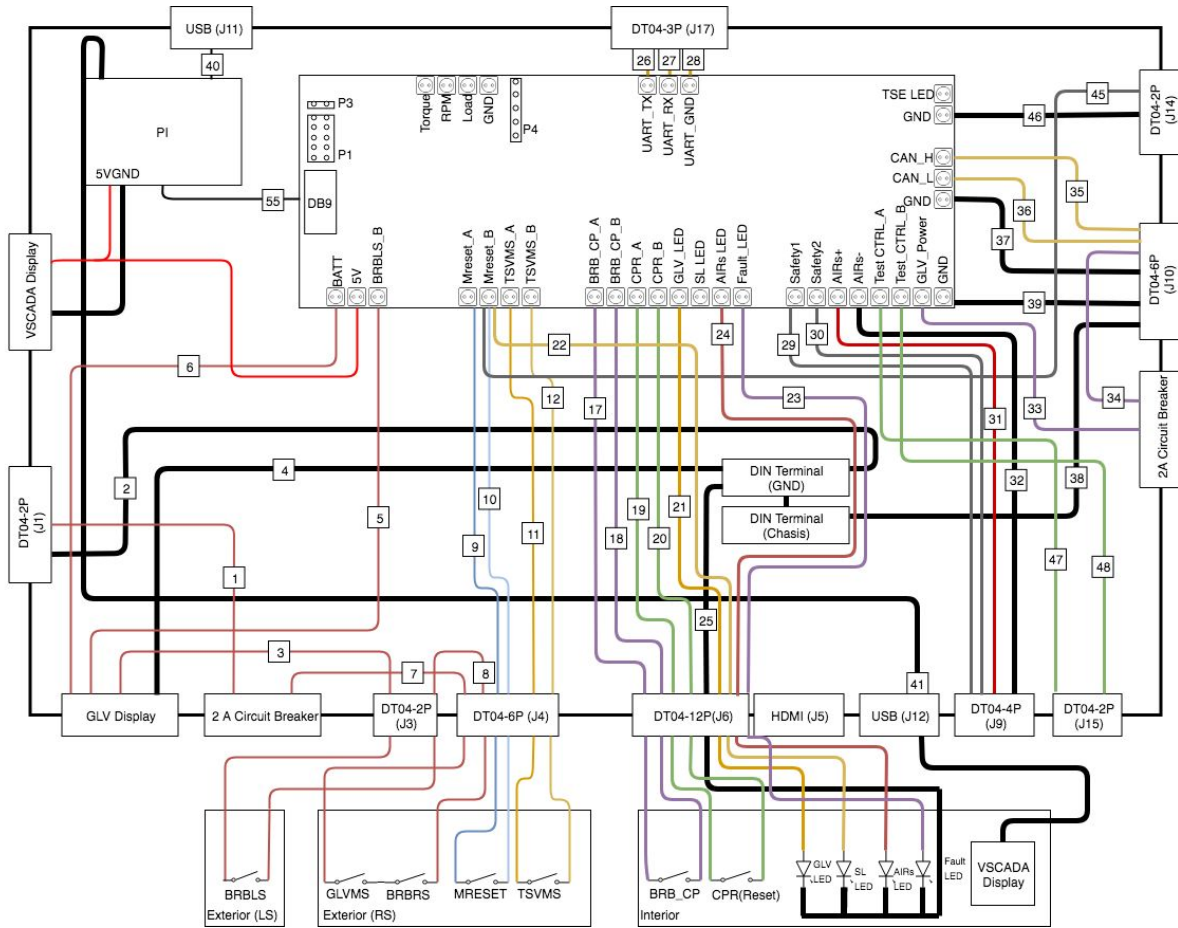

Please refer to the glv wiring diagram for correct wiring

FAQ

1. Why is safety Loop not closed?

Use the terminators starts from the GLV, check if the fault light goes away. If the fault light still exists, then there check if all the pins that goes into the safety port have the correct voltage.

2. Why can't I close the master reset button?

Check there are any burning traces on the board. Also check if there are any loose wires on the brbs to prevent the voltage flowing.