

Accumulator and Dynamometer Experiment: EXP-02

Greg Flynn

This document contains information about how to set up an experiment to drive the dynamometer with the accumulator.

Table of Contents

Desired objectives	3
Required Hardware	3
Required Software	3
Hardware Setup	4
Full accumulator setup	4
Software Setup	5
Data.....	5
Desired data.....	5
Current	5
Temperature	5
Appendix A: Wiring requirements	6

Desired objectives

This experiment should verify the packs can drive the motor. This test is not for data acquisition but it could be modified easily to record information for physics calculations.

In this experiment the load is modified to enable to motor to operate at different torques.

To run these test a safety plan must have already been agreed and accepted by the ECE Director of Laboratories.

Required Hardware

- 4 Packs in series
- Motor load
- Basic GLV safety loop
- PPE per safety plan
- Danger zone per safety plan
- Cables as specified in Appendix A
- Temperature Probe
- Multimeter
- Current probe

Required Software

- TeamViewer

Hardware Setup

Full accumulator setup

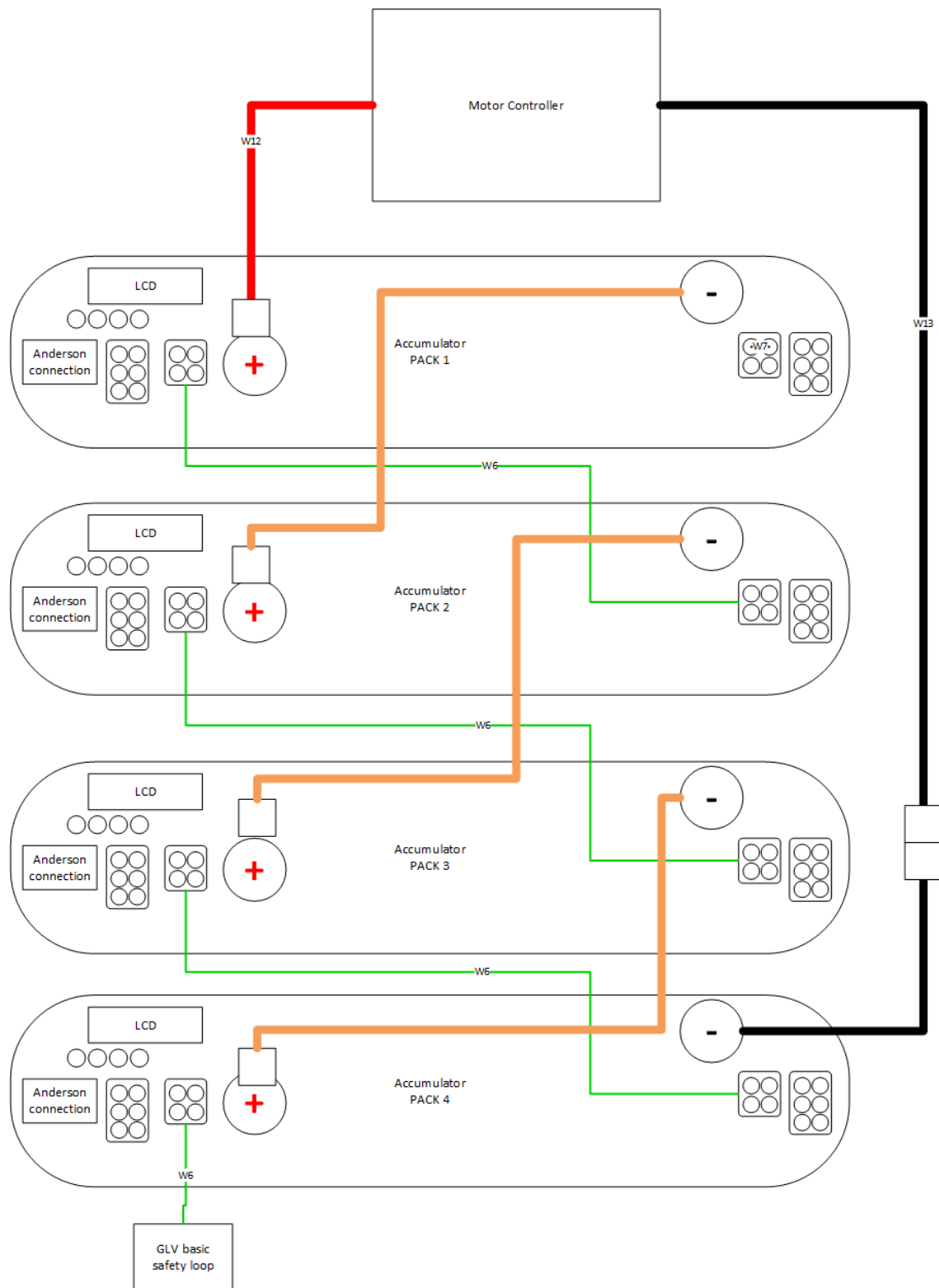

Figure 1 Full 4 cell test

Software Setup

- Turn Test Stand PC on and log in
- Leave the Dyno Room and login into the remote PC.
- Launch Teamviewer and enter the following Partner ID: 554547715.
- Enter the password: AEC401
- Once launched open Oracle VM Virtual Box
- Select openSUSE and press Start
- Once open, Click on the Dyno Icon located on the desktop.
- Enter the password AEC401

Now the GUIs will be displayed and you will be able to control your test from there

Data

Perform full stress test. Ramp the RPM with a given fixed load. Do not adjust the load while the motor is spinning, this could cause RUD of the motor.

Desired data

It is desired to get:

- Torque
- Current
- Cell temperature

Current

Note if the current gets over 200A for a sustained amount of time. The fuses are rated at 200A

Temperature

While testing ensure that no part of the pack gets 40C above ambient temperature.

Witness/examiner signature

Date

Pass/Fail

Appendix A: Wiring requirements

- 1 WHT SL1
- 2 BRN SL2
- 3 RED AIRs+
- 4 BLK AIRs-

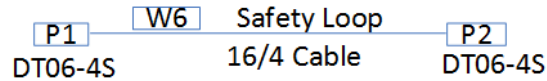

- 1 WHT SL1
- 2 BRN SL2
- 3 RED AIRs+
- 4 BLK AIRs-

- 1 WHT SL1
- 2 BRN SL2
- 3 RED AIRs+
- 4 BLK AIRs-

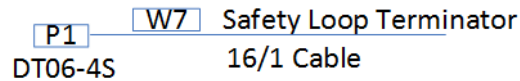

- 1 Jump pin
- 2 1 and 2
- 3 Leave pin
- 4 3 and 4

- 1 RED TSV HV

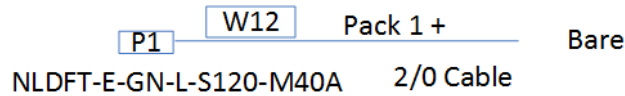

- 1 RED TSV HV

- 1 RED TSV HV

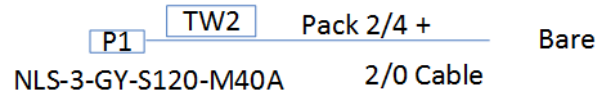

- 1 RED TSV HV

- 1 RED TSV HV

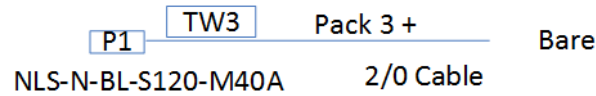

- 1 RED TSV HV

- 1 RED TSV HV

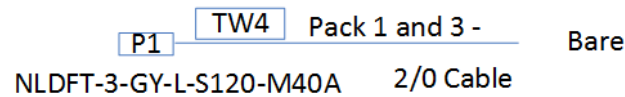

- 1 RED TSV HV

- 1 RED TSV HV

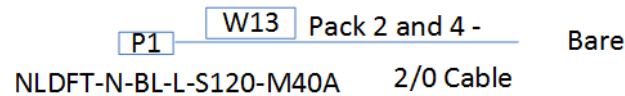

- 1 RED TSV HV

Cable	What packs use it	Total count for full test
W6	1,2,3,4	4
W7	1,2,3,4	1
W12	1	1
TW2	2,4	0
TW3	3	0
TW4	1,3	0
W13	2,4	1