

# Grounded Low Voltage (GLV) Interconnectivity Document

ECE 492 2017

# Contents

- Overview..... 3
- GLV ICD Overview..... 4
- GLV BoB Pinouts..... 7

# Overview

The purpose of this document is to provide wiring and interconnect information about the Grounded Low Voltage box. This document specifically regards the interconnect information for the components within the GLV box. A separate ICD can be found for how the GLV box connects with its external components. All of the images included below are provided in .pdf and original form in the zip folder located here:

For information about GLV and these subsystems, see the User Manual and Maintenance Manual, both of which can be accessed here: <http://sites.lafayette.edu/ece492-sp17/subsystems/glv/>

# GLV ICD Overview

The image below shows a full wiring diagram of all the components within the GLV box. Below is also a corresponding wire lists, listing wire number, A/B connections and voltage for each of the wires. A higher resolution image of this photo can be found at:

[https://sites.lafayette.edu/ece492-sp17/files/2017/01/GLV\\_Board\\_wirelist.pdf](https://sites.lafayette.edu/ece492-sp17/files/2017/01/GLV_Board_wirelist.pdf)

A copy of the wire list can be found at: [https://sites.lafayette.edu/ece492-sp17/files/2017/01/GLV\\_BOX\\_wirelist.pdf](https://sites.lafayette.edu/ece492-sp17/files/2017/01/GLV_BOX_wirelist.pdf)

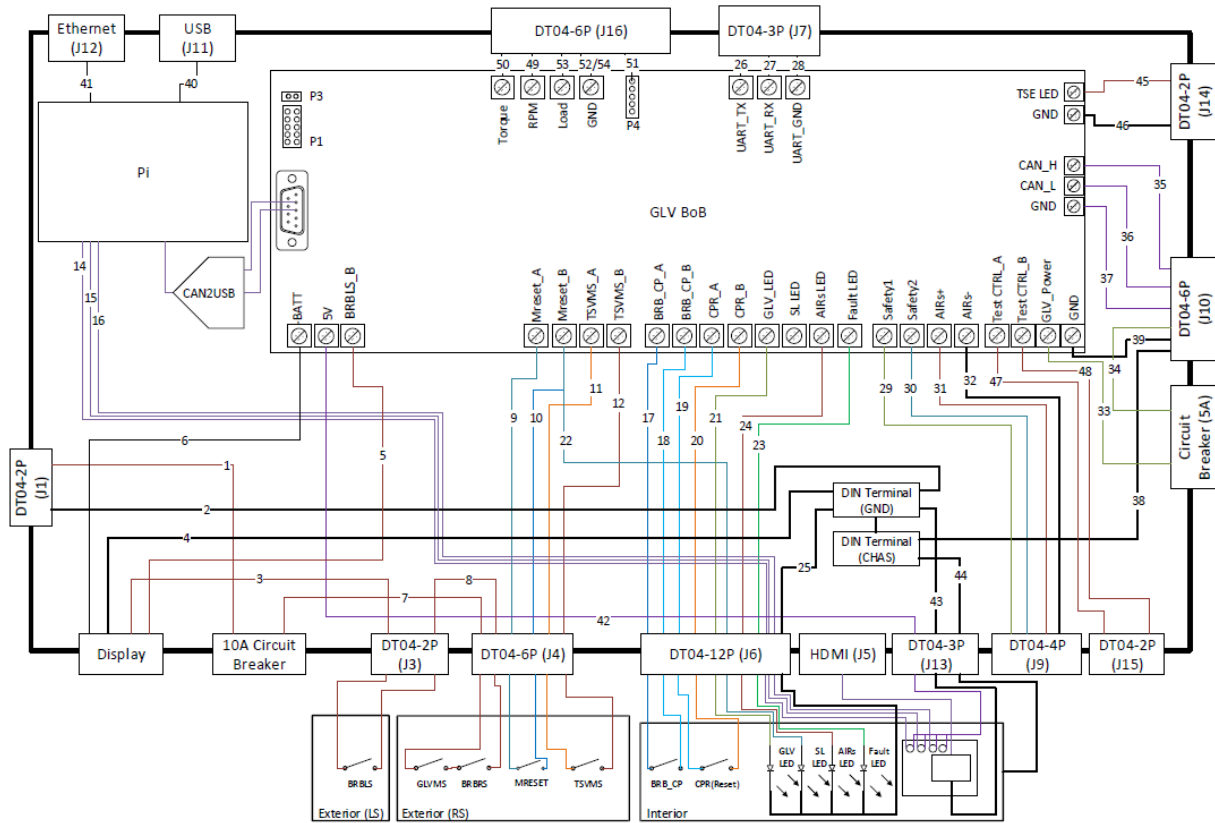

Figure 1: GLV Box Internal Connections

| Wire Number | Conn A           | Conn B                | Voltage |
|-------------|------------------|-----------------------|---------|
| 1           | J1-1             | 15A Circuit Breaker A | 24V     |
| 2           | J1-2             | DIN Terminal (GND)    | GND     |
| 3           | Display (DCin +) | J3-1                  | 24V     |
| 4           | Display (DCin -) | DIN Terminal (GND)    | GND     |
| 5           | Display (Load +) | GLV BoB (BRBLS_B)     | 24V     |

|    |                       |                     |            |
|----|-----------------------|---------------------|------------|
| 6  | Display (Load -)      | GLV BoB (-BATT)     | GND        |
| 7  | 15A Circuit Breaker B | J4-1                | 24V        |
| 8  | J3-2                  | J4-2                | 24V        |
| 9  | J4-3                  | GLV BoB (Mreset_A)  | 24V        |
| 10 | J4-4                  | GLV BoB (Mreset_B)  | 24V        |
| 11 | J4-5                  | GLV BoB (TSVMS_A)   | 24V        |
| 12 | J4-6                  | GLV BoB (TSVMS_B)   | 24V        |
| 13 | J5 (HDMI)             | Pi HDMI             | (HDMI)     |
| 14 | J6-1                  | Pi I/O              | 5V         |
| 15 | J6-2                  | Pi I/O              | 5V         |
| 16 | J6-3                  | Pi I/O              | 5V         |
| 17 | J6-4                  | GLV BoB (BRB_CP_A)  | 24V        |
| 18 | J6-5                  | GLV BoB (BRB_CP_B)  | 24V        |
| 19 | J6-6                  | GLV BoB (CPR_A)     | 24V        |
| 20 | J6-7                  | GLV BoB (CPR_B)     | 24V        |
| 21 | J6-8                  | GLV BoB (GLV_LED)   | 24V        |
| 22 | J6-9                  | GLV BoB (Mreset_A)  | 24V        |
| 23 | J6-10                 | GLV BoB (Fault_LED) | 5V         |
| 24 | J6-11                 | GLV BoB (AIRs_LED)  | 24V        |
| 25 | J6-12                 | DIN Terminal (GND)  | GND        |
| 26 | J7-1                  | GLV BoB (UART_TX)   | 5V (UART)  |
| 27 | J7-2                  | GLV BoB (UART_RX)   | 5V (UART)  |
| 28 | J7-3                  | GLV BoB (UART_GND)  | GND        |
| 29 | J9-1                  | GLV BoB (Safety1)   | 24V        |
| 30 | J9-2                  | GLV BoB (Safety2)   | 24V        |
| 31 | J9-3                  | GLV BoB (AIRs+)     | 24V        |
| 32 | J9-4                  | GLV BoB (AIRs-)     | GND        |
| 33 | 8A Circuit Breaker A  | GLV_BoB (GLV_Power) | 24V        |
| 34 | 8A Circuit Breaker B  | J10-5               | 24V        |
| 35 | J10-1                 | GLV_BoB (CAN_H)     | CAN_H      |
| 36 | J10-2                 | GLV_BoB (CAN_L)     | CAN_L      |
| 37 | J10-3                 | GLV_BoB (GND)       | GND        |
| 38 | J10-4                 | DIN Terminal (CHAS) | GND        |
| 39 | J10-6                 | DIN Terminal (GND)  | GND        |
| 40 | J11 (USB)             | Pi USB              | (USB)      |
| 41 | J12 (Ethernet)        | Pi Ethernet         | (Ethernet) |
| 42 | J13-1                 | GLV_BoB (+5V)       | 5V         |
| 43 | J13-2                 | GLV_BoB (GND)       | GND        |
| 44 | J13-3                 | GLV_BoB (CHAS)      | GND        |

|    |              |                      |                          |
|----|--------------|----------------------|--------------------------|
| 45 | J14-1        | GLV_BoB (TSE_LED)    | 24V                      |
| 46 | J14-2        | GLV_BoB (GND)        | GND                      |
| 47 | J15-1        | GLV_BoB (TestCTRL_A) | Dyno Room<br>supply cntl |
| 48 | J15-2        | GLV_BoB (TestCTRL_B) | Dyno Room<br>supply cntl |
| 49 | J16-1        | GLV_BoB (RPM)        | 5V                       |
| 50 | J16-2        | GLV_BoB (Torque)     | 5V                       |
| 51 | J16-3        | GLV_BoB (P4-1)       | 5V                       |
| 52 | J16-4        | GLV_BoB (GND)        | GND                      |
| 53 | J16-5        | GLV_BoB (Load)       | 5V                       |
| 54 | J16-6        | GLV_BoB (GND)        | GND                      |
| 55 | GLV_BoB (P1) | Pi Pins              | 5V                       |
| 56 | GLV_BoB (P3) | Pi Pins              | 5V                       |

# GLV BoB Pinouts

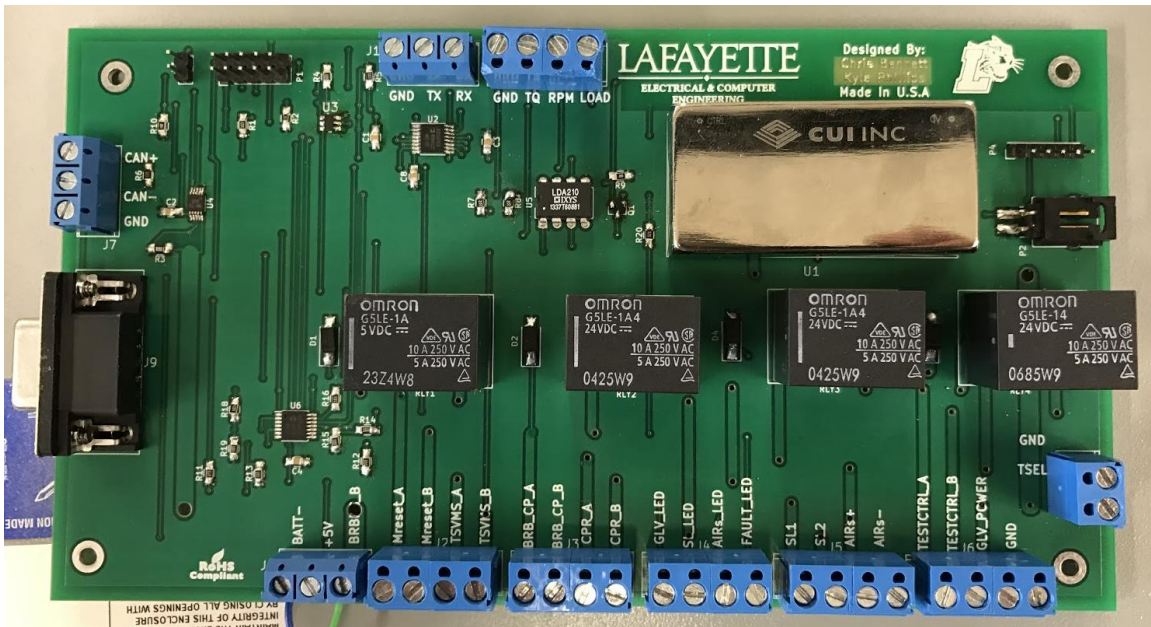

Figure 2: GLV BoB

Almost all the connections on the GLV BoB are made via screw terminals. Ideally you should use stranded wire for these connections as they are more secure connections. The only different types of connections on this board is the 9-pin usb connector used for the CAN2USB line and the header pins which connect to the Pi. The 10pin header connection P1 can connect directly to the top 10 pins of the Pi via a 10 pin ribbon cable. The Ctrl signal is a GPIO pin that can be used by the Pi to open or close the VSCADA relay.

Raspberry Pi 2 Model B (J8 Header) pinout

| WiringPi      | BCM(Name)      | Physical | Physical | BCM(Name)      | WiringPi |
|---------------|----------------|----------|----------|----------------|----------|
| 3v3 Power     |                | 1        | 1        | 3v3 Power      |          |
| 8             | BCM 2 (SDA)    | 3        | 3        | 5v Power       |          |
| 9             | BCM 3 (SCL)    | 5        | 5        | Ground         |          |
| 7             | BCM 4 (GCLK0)  | 7        | 7        | BCM 14 (TXD)   | 15       |
| Ground        |                | 9        | 9        | BCM 15 (RXD)   | 16       |
| 0             | BCM 17         | 11       | 11       | BCM 18 (PCM_C) | 1        |
| 2             | BCM 27 (PCM_D) | 13       | 13       | Ground         |          |
| 3             | BCM 22         | 15       | 15       | BCM 23         | 4        |
| 3v3 Power     |                | 17       | 17       | BCM 24         | 5        |
| 12            | BCM 10 (MOSI)  | 19       | 19       | Ground         |          |
| 13            | BCM 9 (MISO)   | 21       | 21       | BCM 25         | 6        |
| 14            | BCM 11 (SCLK)  | 23       | 23       | BCM 8 (CE0)    | 10       |
| Ground        |                | 25       | 25       | BCM 7 (CE1)    | 11       |
| BCM 0 (ID_SD) |                | 27       | 27       | BCM 1 (ID_SC)  |          |
| 21            | BCM 5          | 29       | 29       | Ground         |          |
| 22            | BCM 6          | 31       | 31       | BCM 12         | 26       |
| 23            | BCM 13         | 33       | 33       | Ground         |          |
| 24            | BCM 19 (MISO)  | 35       | 35       | BCM 16         | 27       |
| 25            | BCM 26         | 37       | 37       | BCM 20 (MOSI)  | 28       |
| Ground        |                | 39       | 39       | BCM 21 (SCLK)  | 29       |

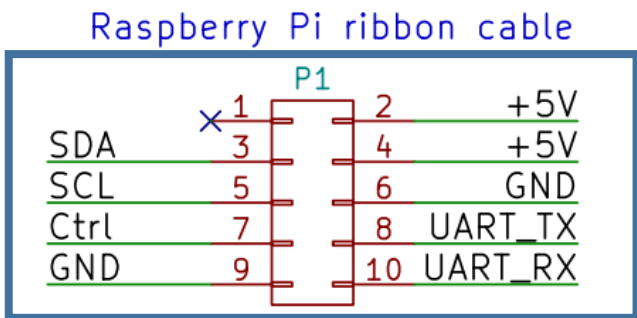

Figure 3: Pi Pin connections

In ad provides two logic high or logic low (5V) signals to G110 (General Purpose Input Output) pins

Figure 4: Pi Pin Connections

on the Pi in order to deliver the status of the safety loop. The P4 header provides additional input/output ports for the ADC/DAC on board the GLV BoB. However, Pin 1 on P4 is specifically an output.