

Lafayette College | Electrical and Computer Engineering

# Motor Controller Cooling System (MCCS) Maintenance Manual

ECE 492 Spring 2017

## Table of Contents

<b>Overview</b>	3
<b>Safety</b>	4
<b>Electrical System Components Maintenance</b>	4
<b>Maintenance</b>	5
<b>System Connections</b>	8
PANNEL 1:	10
SAFETY LOOP Panel (Left Side) – J1	10
SAFETY LOOP Panel (Middle) – J3	10
CAN and POWER Panel (Right Side) – J4	11
PANNEL 2:	11
Pump and Sensors (left side) – J6	11
Pump and Sensors (Middle) – J5	11
CAN and POWER Panel (Right Side) – J2	12
<b>Troubleshooting</b>	12

## Overview

This Motor Controller Cooling System (*MCCS will be used in the rest of this document*) Maintenance Manual documents maintenance instructions for the *MCCS* system.

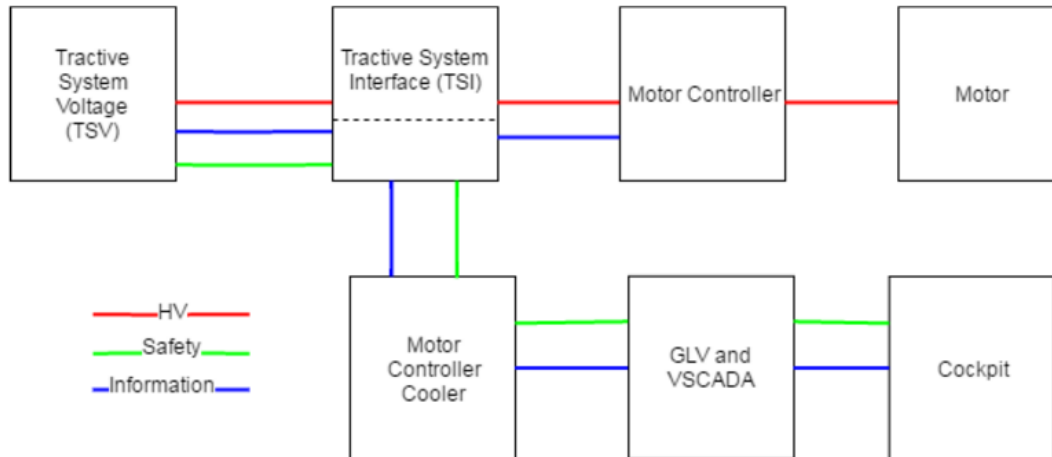

*(Overall Simplified System Connection Diagram)*

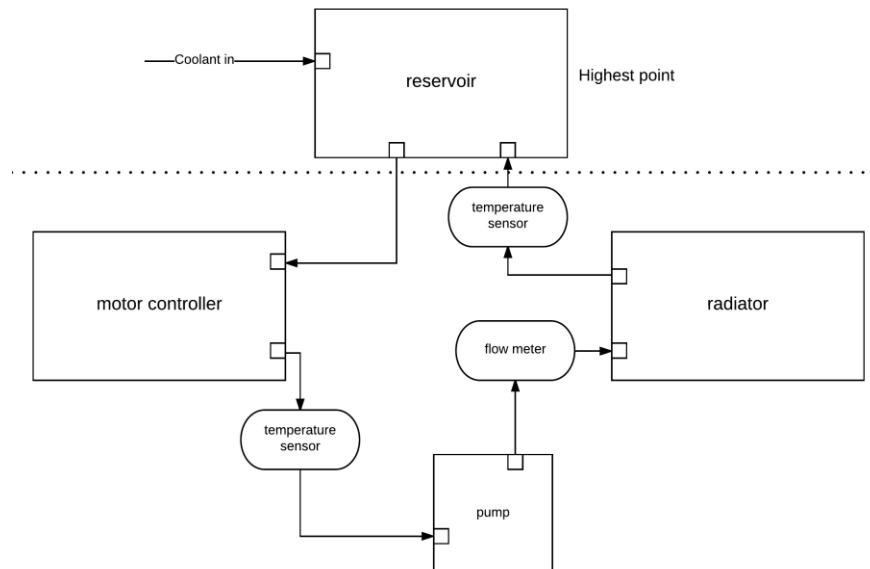

*(Coolant Flow Diagram/Connection of Cooling Components)*

# Safety

The 2017 LFEV team utilized the safety procedures and guidelines set forth by previous LFEV teams. In general, personal protective equipment (PPE; consisting of eye protection, cotton clothing, close-toed shoes, etc) was utilized in a designated workspace with a 1 m barrier distance with a safety watch procedure enacted each time a pack was opened.

Safety documents detailing procedures, expectations and guidelines produced by previous LFEV teams and to which the 2017 LFEV team adhered can be found here:

<http://sites.lafayette.edu/ece492-sp15/files/2015/02/SafetyPlan.pdf>

<https://sites.lafayette.edu/ece492-sp16/files/2016/03/2016SafetyPlan.pdf>

# Electrical System Components Maintenance

This diagram shows all the electrical connections on the central controller, one Arduino UNO R3. The detailed explanations of how internally/externally the pins are connected to various parts can be found in ICD documents of MCCS.

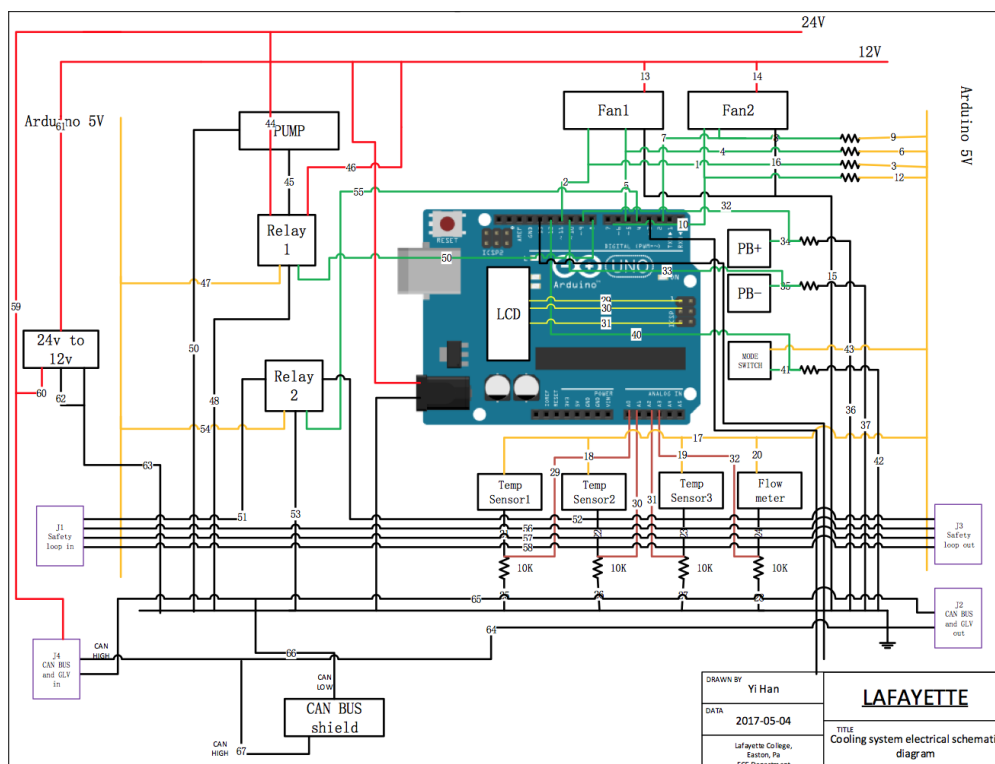

# Maintenance

## 1. Pump:

- [Koolance PMP-450s](#)
- Should be connected to 24V DC power.
- Maximum Flow Rate: 12L/min (3.2 gal/min) @ 12V, 20L/min (5.3 gal/min) @ 24V
- Maximum Head Pressure: 3.2m (10.5ft) @ 12V, 6m (19.7ft) @ 24V
- Motor: Brushless DC, electronically commutated, spherical motor
- Power: 8-24VDC, 3-50W, 0.13-2.1A
- Startup Voltage: 9 to 13.2 VDC
- Maximum System Pressure: 3.5 kgf/cm<sup>2</sup> (50 PSI)
- Maximum Temperature: 60°C (140°F)
- Electrical Connector: 4-pin Molex power supply connection + 3-pin (single lead) tach
- Hose Connections: 13mm (1/2in) ID hose barbs
- Wetted Materials: PPO, Carbon/Allumina Ceramic, EPDM or Viton, 316 SS
- Noise: Less than 40dBA
- Weight: 862g (1.9lbs)
- MTBF 50k hours

## 2. Fan/Radiator:

- Fans are working on 12V DC power, so a DC-DC 24V-12V converter is being used to convert the overall 24V GLV power to 12V.
- Speed: 1200RPM±10%
- Air Flow: 41.4CFM
- Air Pressure: 1.21mm-H<sub>2</sub>O
- Noise Level: 16dB(A)
- Input Power: 3.3W
- Rated Voltage: DC12V
- Input Current: 0.28A
- Cable length: 40cm / 15.7in
- Product Specification:  
120mm(W)\*120mm(D)\*25mm(H)/4.7in(W)\*4.7in(D)\*1in(H)

- Packing Size: 135mm(W)\*135mm(D)\*30mm(H)/5.5in(W)\*5.5in(D)\*1.25in(H)

### 3. Relay(s):

- The [\*KEYES 5V Relay Module\*](#) is powered by 5V output power from Arduino UNO R3 and controlled by a digital pin from Arduino UNO R3. The maximum DC current and voltage are 10A and 30VDC, so it can be used to switch 24V/12V DC voltage and be used to tap into the 24V GLV safety loop.
- 5V – 12 V TTL control signal
- Maximum AC current and voltage : 10A 250VAC
- Maximum DC current and voltage : 10A 30VDC
- The control signal DC or AC, 220V AC load can be controlled
- There is a normally open and one normally closed contact
- To make the coil of relay energized you must need to have an input of 1 in the signal pin.

### 4. Low Power Components:

- Parts like pushbuttons, switches and different types of sensors can be directly powered by 5V Arduino output power.

### 5. Arduino:

- Arduino UNO R3 can only source a total of 200mA; operating voltage should not exceed 12V.
- Microcontroller ATmega328
- Operating Voltage 5V
- Input Voltage (recommended) 7-12V
- Input Voltage (limits) 6-20V
- Digital I/O Pins 14 (of which 6 provide PWM output)
- Analog Input Pins 6 DC Current per I/O Pin 40 mA
- DC Current for 3.3V Pin 50 mA
- Flash Memory 32 KB (ATmega328) of which 0.5 KB used by bootloader
- SRAM 2 KB (ATmega328)
- EEPROM 1 KB (ATmega328)
- Clock Speed 16 MHz



- All surface mount design allows a backpack that is half the size of the original
- Faster boot-up time
- Boot-up display can be turned on/off via firmware
- User definable splash screen

## System Connections

- Internal System Connection:
  - Can be found in MCCS Internal ICD. But here is a schematic diagram:

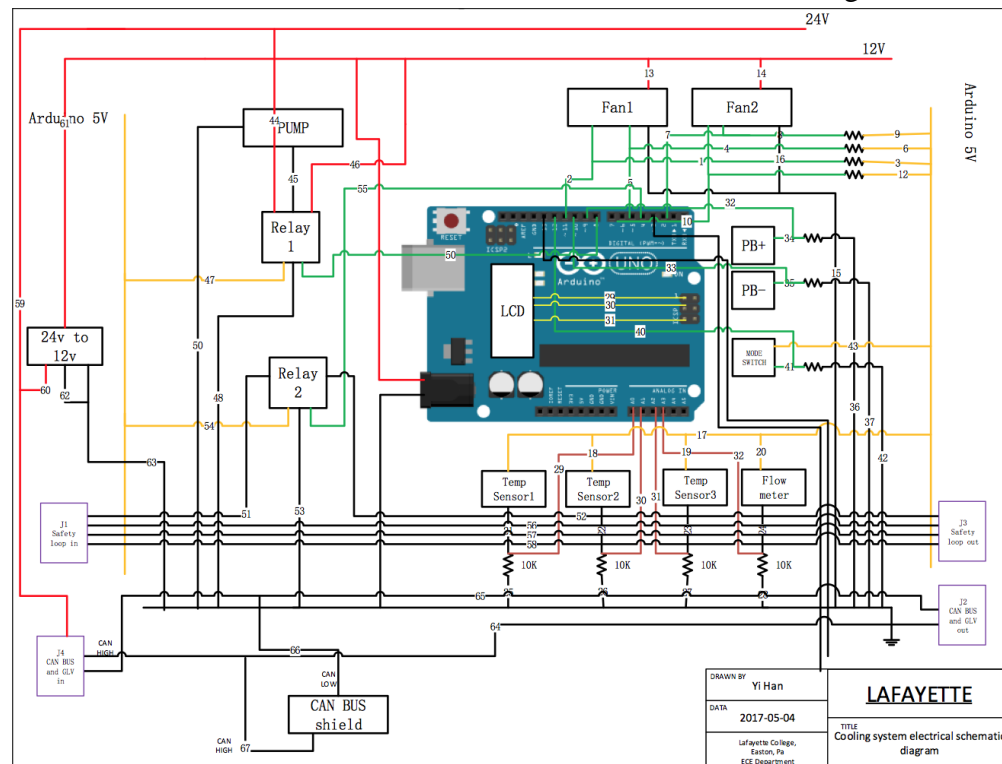

Wire Number	Conn A	Conn B	Voltage
1	FAN1 PWM	10K Resistor	N/A
2	FAN1 PWM	DIGITAL 11	N/A
3	10K Resistor	Arduino 5V	5V
4	FAN1 Tachometer	10K Resistor	N/A
5	FAN1 Tachometer	DIGITAL 5	N/A
6	10K Resistor	Arduino 5V	5V
7	FAN2 Tachometer	10K Resistor	N/A



8	FAN2 Tachometer	DIGITAL 2	N/A
9	10K Resistor	Arduino 5V	5V
10	FAN2 PWM	DIGITAL 6	N/A
11	FAN2 PWM	10K Resistor	N/A
12	10K Resistor	Arduino 5V	5V
13	FAN1 Power	12V	12V
14	FAN2 Power	12V	12V
15	FAN1 GND	GND	GND
16	FAN2 GND	GND	GND
17	TEMP SENSOR1 PIN1	Arduino 5V	5V
18	TEMP SENSOR2 PIN1	Arduino 5V	5V
19	TEMP SENSOR3 PIN1	Arduino 5V	5V
20	FLOW METER PIN1	Arduino 5V	5V
21	TEMP SENSOR1 PIN2	10K Resistor	N/A
22	TEMP SENSOR2 PIN2	10K Resistor	N/A
23	TEMP SENSOR3 PIN2	10K Resistor	N/A
24	FLOW METER PIN2	10K Resistor	N/A
25	TEMP SENSOR1 PIN2	A0	N/A
26	TEMP SENSOR2 PIN2	A1	N/A
27	TEMP SENSOR3 PIN2	A2	N/A
28	FLOW METER PIN2	A3	N/A
29	LCD TX	RX	N/A
30	LCD +	LCD + on Arduino	N/A
31	LCD -	LCD - on Arduino	N/A
32	PB1 GND	DIGITAL 9	N/A
33	PB2 GND	DIGITAL 10	N/A
34	PB1 GND	10K Resistor	N/A
35	PB2 GND	10K Resistor	N/A
36	10K Resistor	GND	GND
37	10K Resistor	GND	GND
38	PB1 POWER	Arduino 5V	5V
39	PB2 POWER	Arduino 5V	5V
40	MODE SWICH GND	DIGITAL 12	N/A
41	MODE SWICH GND	10K Resistor	N/A
42	10K Resistor	GND	GND
43	MODE SWICH POWER	Arduino 5V	5V
44	RELAY1 PIN1	24V	24V
45	RELAY1 PIN2	PUMP POWER	N/A
46	RELAY1 PIN3	12V	12V
47	RELAY1 POWER	Arduino 5V	5V
48	RELAY1 GND	GND	GND

49	RELAY1 S	DIGITAL 8	N/A
50	PUMP GND	GND	GND
51	RELAY2 PIN1	SAFETY LOOP1 IN	N/A
52	RELAY2 PIN2	SAFETY LOOP1 OUT	N/A
53	RELAY2 GND	GND	GND
54	RELAY2 POWER	Arduino 5V	5V
55	RELAY2 S	DIGITAL 4	N/A
56	J1	J5	N/A
57	J1	J5	N/A
58	J1	J5	N/A
59	J4	24V	N/A
60	24V	DC TO DC CONVERTOR	24V
61	DC TO DC CONVERTOR	12V	12V
62	DC TO DC CONVERTOR	GND	GND
63	DC TO DC CONVERTOR	GND	GND
64	J4	J2	N/A
65	J4	J2	N/A
66	CAN BUS SHILED	J2	N/A
67	CAN BUS SHILED	J2	N/A

- External System Connection:

**PANNEL 1:**

**SAFETY LOOP Panel (Left Side) – J1**

Connector Type: DT04-4P Panel Mount

Pin 1: Safety loop input wire 1

Pin 2: Safety loop input wire 2

Pin 3: Safety loop input wire 3

Pin 4: Safety loop input wire 4

**SAFETY LOOP Panel (Middle) – J3**

Connector Type: DT04-4P Panel Mount

Pin 1: Safety loop output wire 1

Pin 2: Safety loop output wire 2

Pin 3: Safety loop output wire 3

Pin 4: Safety loop output wire 4

#### **CAN and POWER Panel (Right Side) – J4**

Connector Type: DT04-6P Panel Mount

Pin 1: CAN H

Pin 2: CAN L

Pin 3: SHIELD

Pin 4: CHGND

Pin 5: 24VDC

Pin 6: 24V RTN

#### **PANNEL 2:**

#### **Pump and Sensors (left side) – J6**

Connector Type: DT04-8P Panel Mount

Pin 1: Pump POWER

Pin 2: Pump GND

Pin 3: Sensors 5V

Pin 4: TEMP SENSOR 1 INPUT

Pin 5: TEMP SENSOR 2 INPUT

Pin 6: TEMP SENSOR 3 INPUT

Pin 7: FLOW METER INPUT

Pin 8: N/A

#### **Pump and Sensors (Middle) – J5**

Connector Type: DT04-8P Panel Mount

Pin 1: FANs POWER

Pin 2: FANs GND

Pin 3: FAN1 PWM

Pin 4: FAN2 PWM

Pin 5: FAN3 tachometer

Pin 6: FAN4 tachometer

Pin 7: N/A

Pin 8: N/A

### **CAN and POWER Panel (Right Side) – J2**

Connector Type: DT04-6P Panel Mount

Pin 1: CAN H

Pin 2: CAN L

Pin 3: SHIELD

Pin 4: CHGND

Pin 5: 24VDC

Pin 6: 24V RTN

## Troubleshooting

### Arduino:

1. Check whether Arduino driver is successfully installed.
2. Check whether COM Port is set to the actual Arduino COM Port.
3. Make sure have the SparkFun CAN libray integrated with Arduino.

### Board:

1. Resistors should be used when connect Arduino with sensors. Detailed connection construction can be found in *ICD*, which can be found on LFEV website also.
2. Note: for Arduinos with 1 VCC pin can source a total of 200mA; Arduino UNO is one of the ones with only 1 VCC pin.

ARDUINO UNO / Duemilanove CURRENT SOURCE/SINK LIMITS

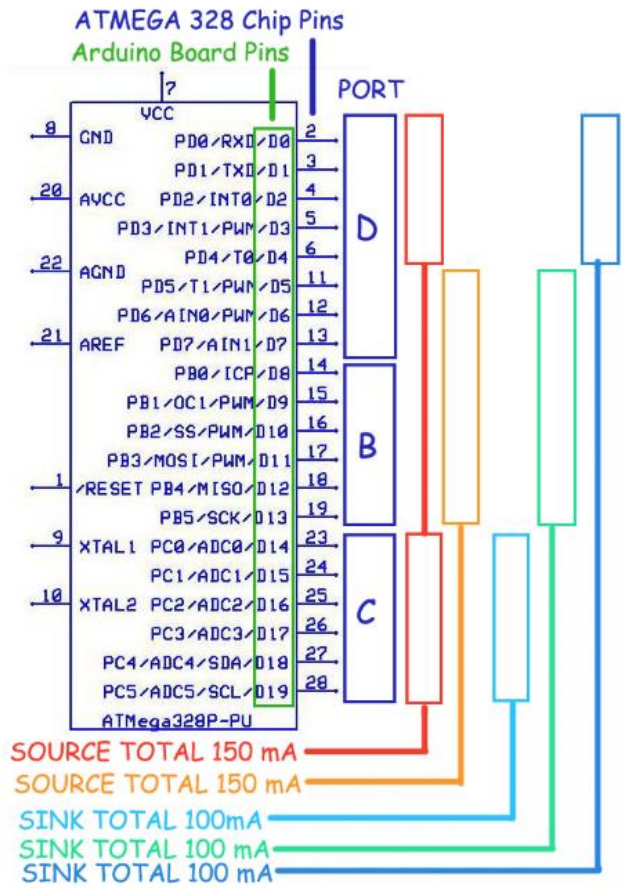

ABSOLUTE MAXIMUM PER PIN 40 mA - RECOMMENDED 20 mA

(<http://playground.arduino.cc/Main/ArduinoPinCurrentLimitations>)