

REQUIRED PARTS				
ITEM	QTY	PART NAME	DESCRIPTION	STEP USED
1	1	TURRET RING	BASE OF TURRET SUBASSEMBLY	WATER JET PART, ALL CUTS AND HOLES ARE THROUGH ALL
2	4	TURRET MOUNTED TURRET SLIDERS	ARCS OF PLASTIC THAT SUPPORT TURRET	WATER JET PART THEN COUNTERSINK HOLES THE COUNTERSINK IS DRAWN AS THE DIMENSIONS OF THE SCREW WHICH IS INTENDED TO BE FLUSH MOUNTED.
3	2	MAST CROSSBAR T BRACKET	T BRACKETS TO MOUNT CROSSBAR AND MAIN MAST TOGETHER	CUT TO SIZE, FILLET, DRILL HOLES
4	2	LINEAR ACTUATOR BOTTOM BRACKET	BRACKETS THAT MOUNT LINEAR ACTUATOR TO TURRET	CUT TO SIZE, FILLET, DRILL HOLES
5	1	CROSSBAR	CROSSBAR THAT SUPPORTS SOLAR PANEL	CUT TO LENGTH, DRILL HOLES
6	1	MAIN MAST	MAST THAT SUPPORTS CROSSBAR	CUT TO LENGTH, DRILL HOLES
7	1	SOLAR PANEL PIN	PIN TO HOLD IN SOLAR PANEL	MCMaster SUPPLIED UHMW, 24"x24"x3/16" (8752K412)

FASTENERS REQUIRED					
ITEM	QTY	PART NAME	DESCRIPTION	MATERIAL	STEP USED
	?????	#10 BLIND RIVET	ALUMINUM BLIND RIVET, 3/16" DIAMETER, FOR 0.126"-0.25" MATERIAL THICKNESS	MCMaster SUPPLIED ALUMINUM RIVETS, 3/16" DIAMETER (97447A050)	
	?????	3/8" 10-32 FLAT HEAD SCREW	FLAT HEAD SCREW 10-32 THREAD SIZE, 3/8" LONG	MCMaster SUPPLIED BLACK-OXIDE ALLOY STEEL HEX DRIVE FLAT HEAD SCREW (91253A001)	1
	3	1/2" 10-32 BUTTON HEAD SCREW	BUTTON HEAD SCREW 10-32 THREAD SIZE, 1/2" LONG	MACHINE SHOP SUPPLIED BLACK-OXIDE ALLOY STEEL HEX DRIVE BUTTON HEAD SCREW	
	3	1/4" 10-32 BUTTON HEAD SCREW	BUTTON HEAD SCREW 10-32 THREAD SIZE, 1/4" LONG	MACHINE SHOP SUPPLIED BLACK OXIDE ALLOY STEEL HEX DRIVE BUTTON HEAD SCREW	
	4	2 3/4" 10-32 BUTTON HEAD SCREW	BUTTON HEAD SCREW 10-32 THREAD SIZE, 2 3/4" LONG	MACHINE SHOP SUPPLIED BLACK-OXIDE ALLOY STEEL HEX DRIVE BUTTON HEAD SCREW	
	3	1 1/4" 1/4-20 SOCKET HEAD SCREW	SOCKET HEAD SCREW 1/4-20 THREAD SIZE, 1 1/4" LONG	MCMaster OR MACHINE SHOP SUPPLIED STEEL HEX DRIVE SOCKET HEAD SCREW	
	4	3/4" 1/4-20 HEX HEAD SCREW	HEX HEAD SCREW 1/4-20 THREAD SIZE, 3/4" LONG	MCMaster OR MACHINE SHOP SUPPLIED STEEL HEX HEAD SCREW	
	????	#10 WASHER	WASHER FOR #10 SCREW SIZE, 0.203" ID, 0.438" OD	MCMaster SUPPLIED ALUMINUM WASHER (93286A011)	
	3	1/4-20 WASHER	WASHER FOR 1/4" SCREW SIZE	MCMaster OR SHOP SUPPLIED WASHER	
	????	10-32 NYLON INSERT NUT	THIN NYLON INSERT NUT	MCMaster SUPPLIED LOW-STRENGTH STEEL THIN NYLON-INSERT LOCKNUT	
	3	1/4-20 NYLON INSERT NUT	NYLON INSERT NUT	MCMaster OR SHOP SUPPLIED STEEL NYLON-INSERT LOCKNUT	

DRAWN groteh	3/8/2023	LAFAYETTE ECE DIVISION		
CHECKED cironer		TITLE		
QA		TURRET ASSEMBLY INSTRUCTIONS		
MFG				
APPROVED weyt		SIZE D	DWG NO 24	REV A
		SCALE	SHEET 1 OF 5	

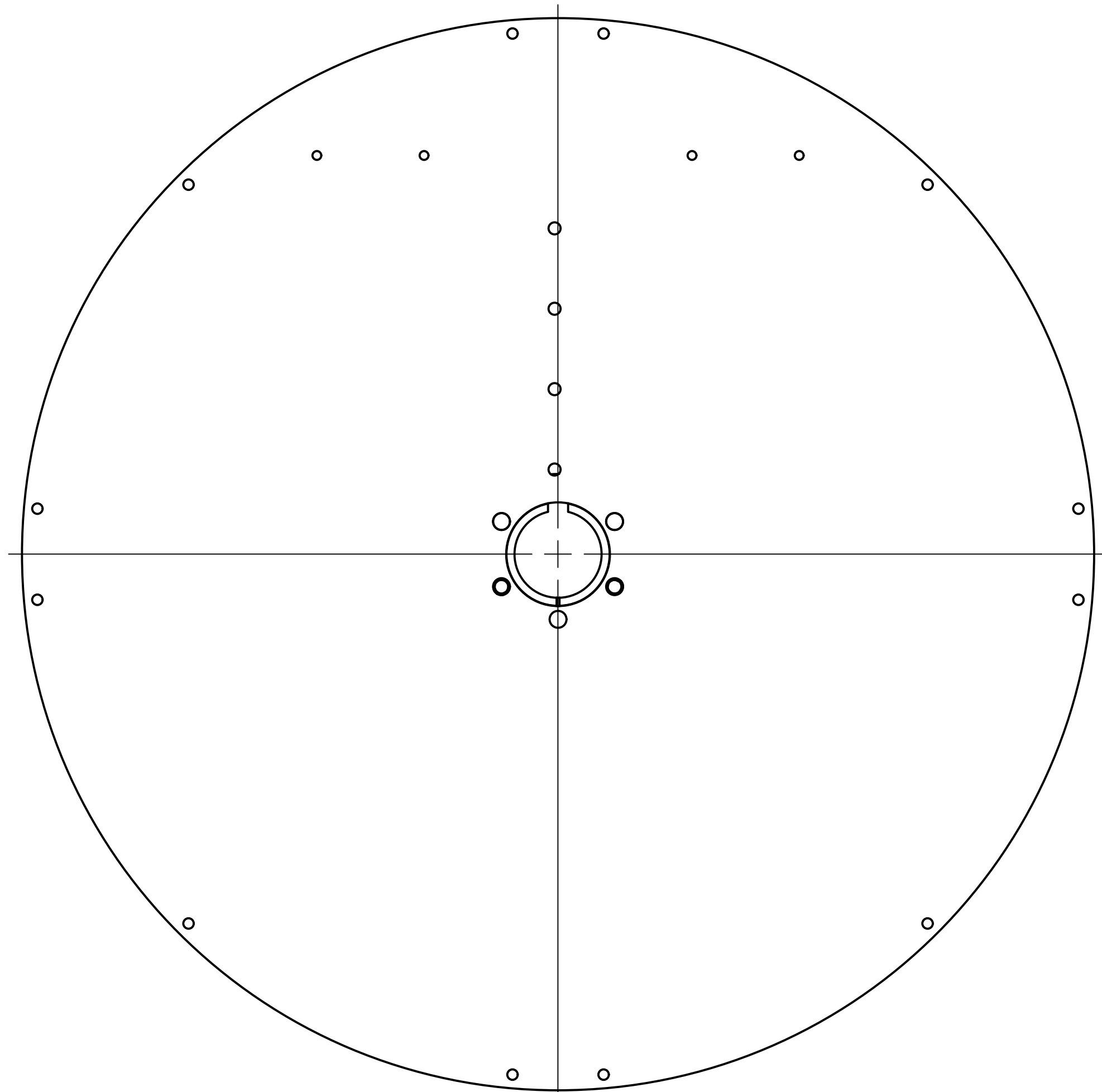

STEP n

INSTRUCTIONS:

- PARTS REQUIRED:
 12 x 3/8" 10-32 FLAT HEAD SCREW
 3 x
 4 x 3/8" 8-32 FLAT/BUTTON HEAD SCREW
 2 x 2 1/2" FLAT/BUTTON HEAD SCREW

DRAWN groteh	3/8/2023	LAFAYETTE ECE DIVISION		
CHECKED cironer		TITLE		
QA		TURRET ASSEMBLY INSTRUCTIONS		
MFG		SIZE D	DWG NO 24	REV A
APPROVED weyt		SCALE 1 / 2	SHEET 2 OF 5	

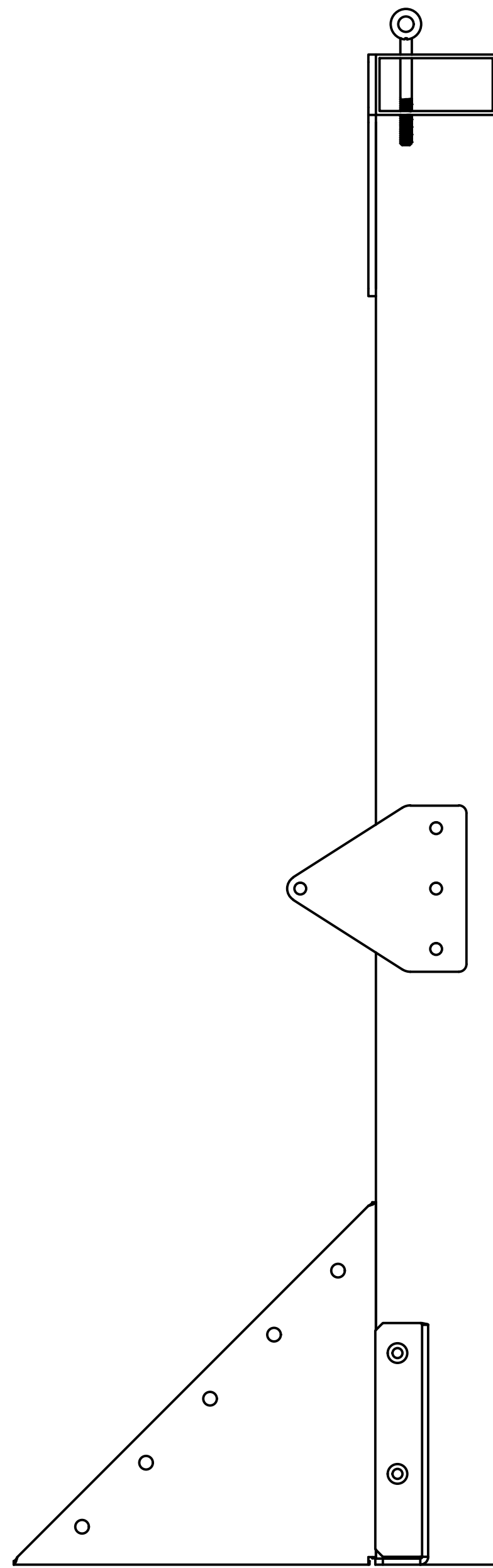
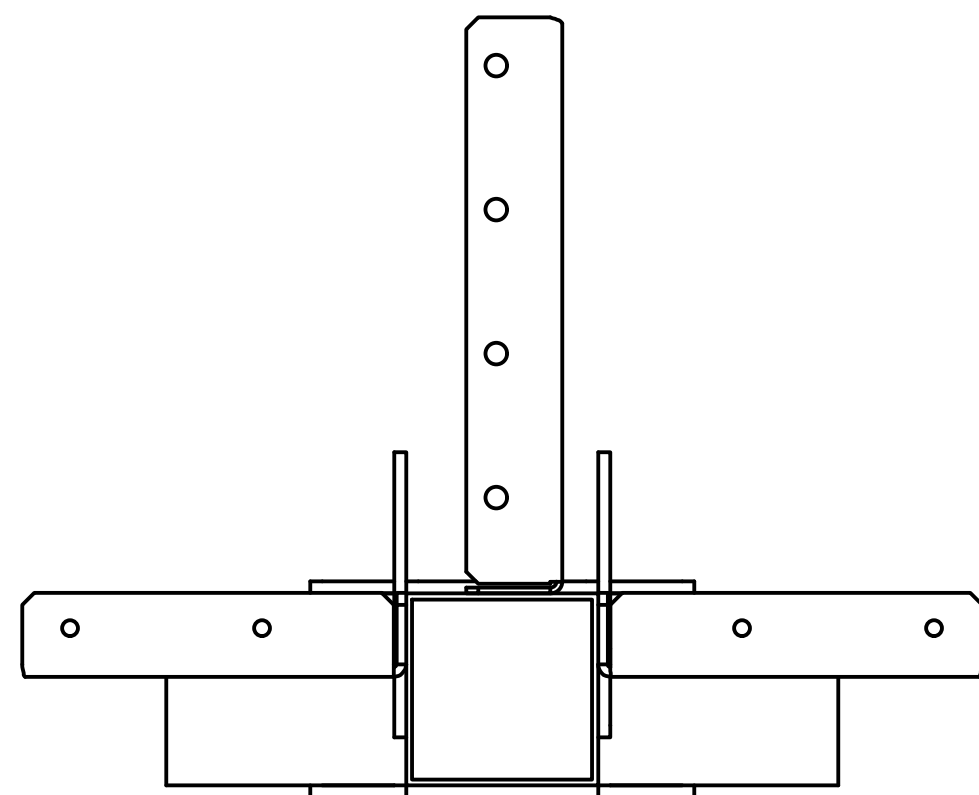
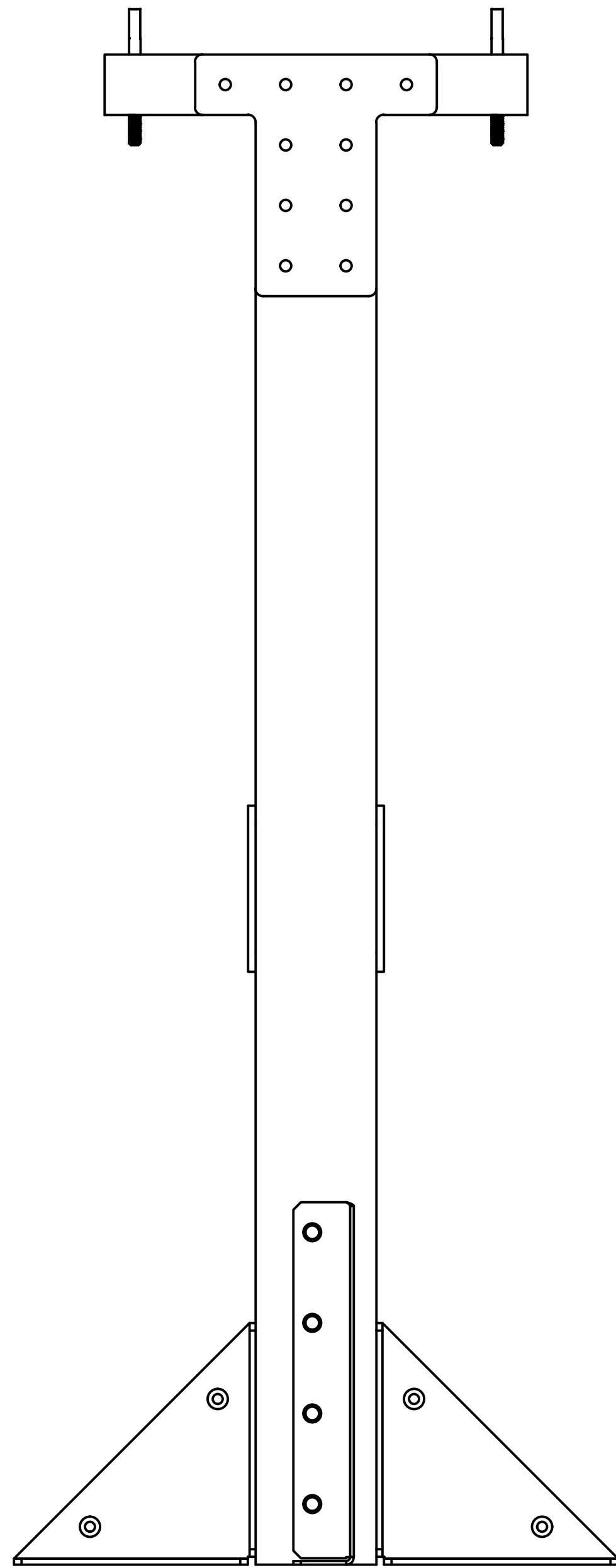

DRAWN groteh	3/8/2023	LAFAYETTE ECE DIVISION		
CHECKED cironer		TITLE		
QA		TURRET ASSEMBLY INSTRUCTIONS		
MFG		SIZE D	DWG NO 24	REV A
APPROVED weyt		SCALE 1 / 2	SHEET 3 OF 5	

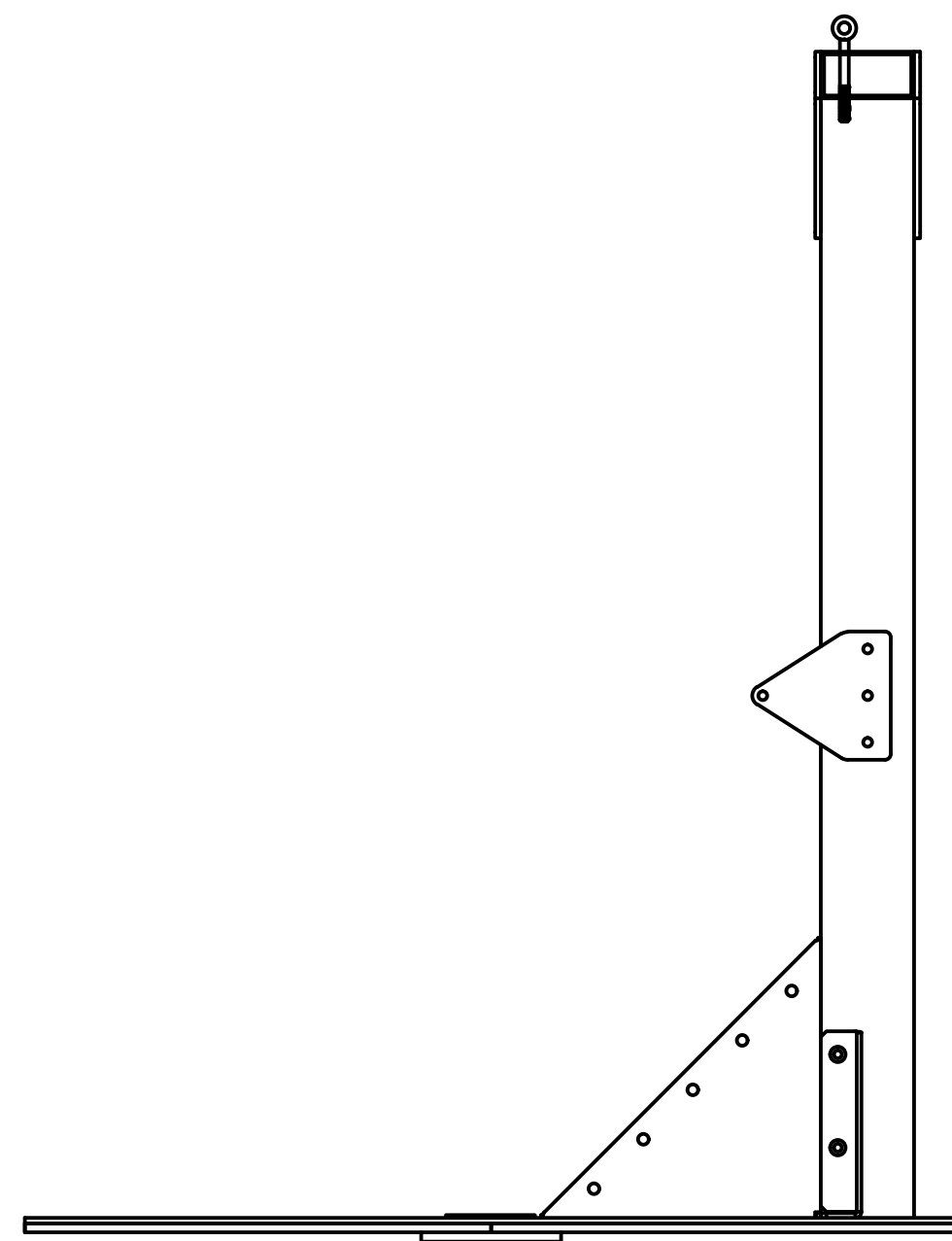
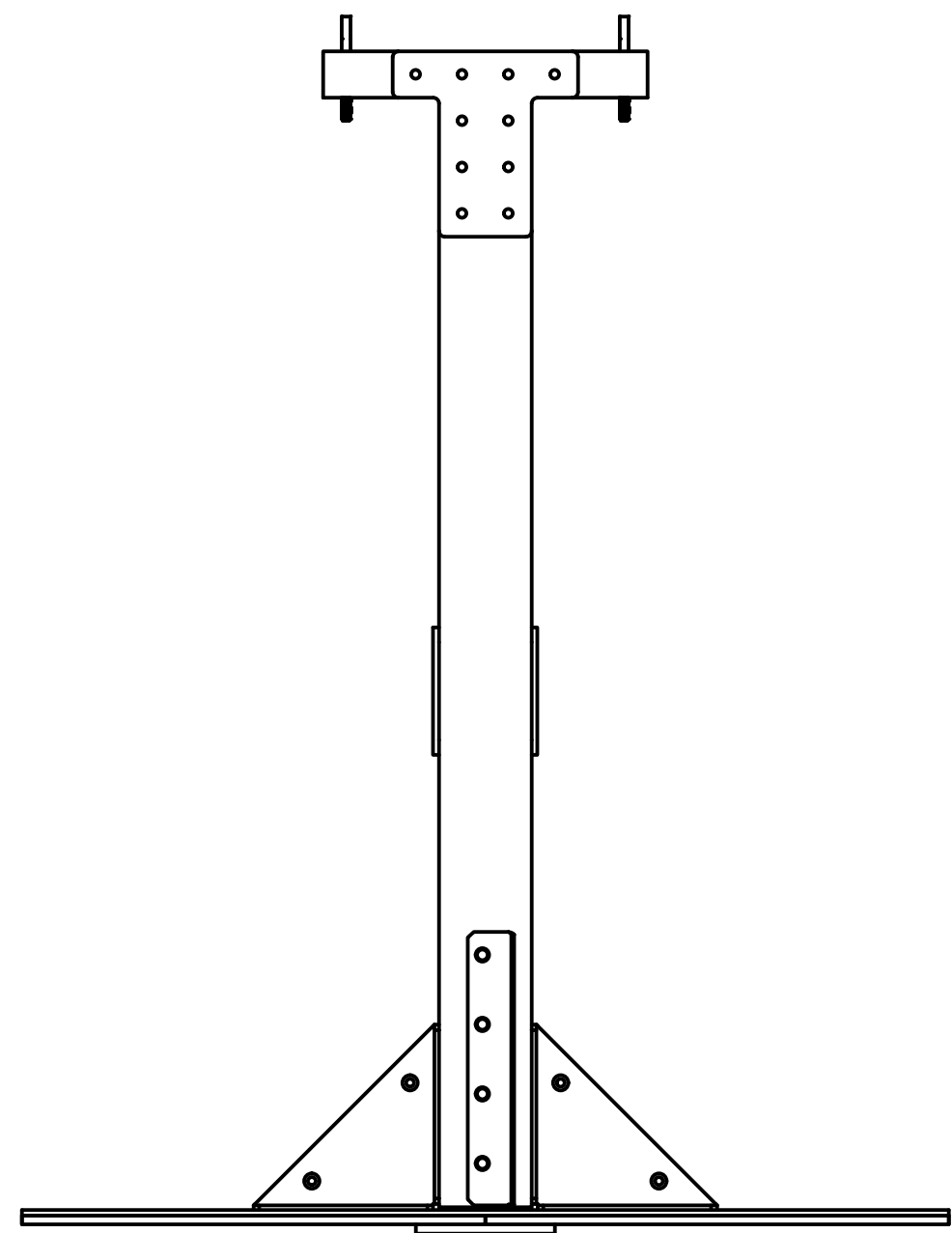
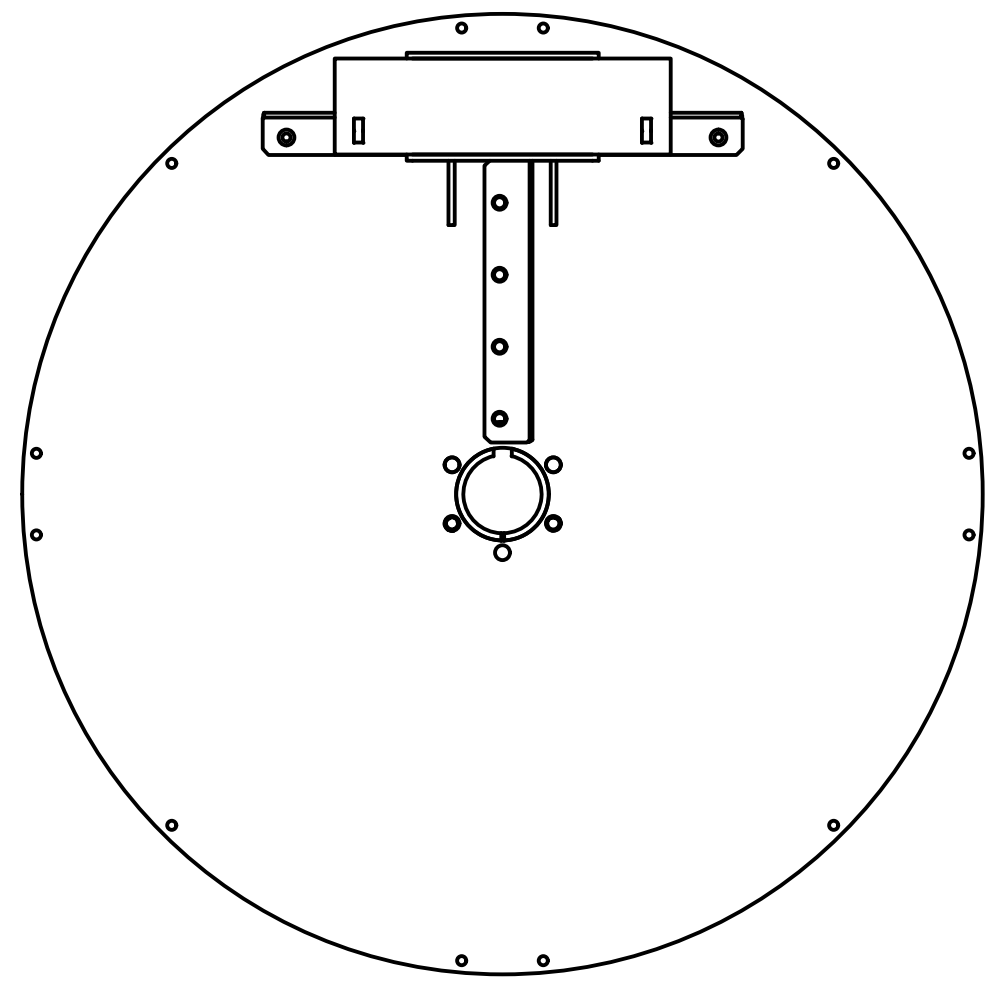

DRAWN groteh	3/8/2023	LAFAYETTE ECE DIVISION		
CHECKED cironer		TITLE		
QA weyt		TURRET ASSEMBLY INSTRUCTIONS		
MFG		SIZE D	DWG NO 24	REV A
APPROVED		SCALE 1 / 4	SHEET 4 OF 5	

8 7 6 5 4 3 2 1

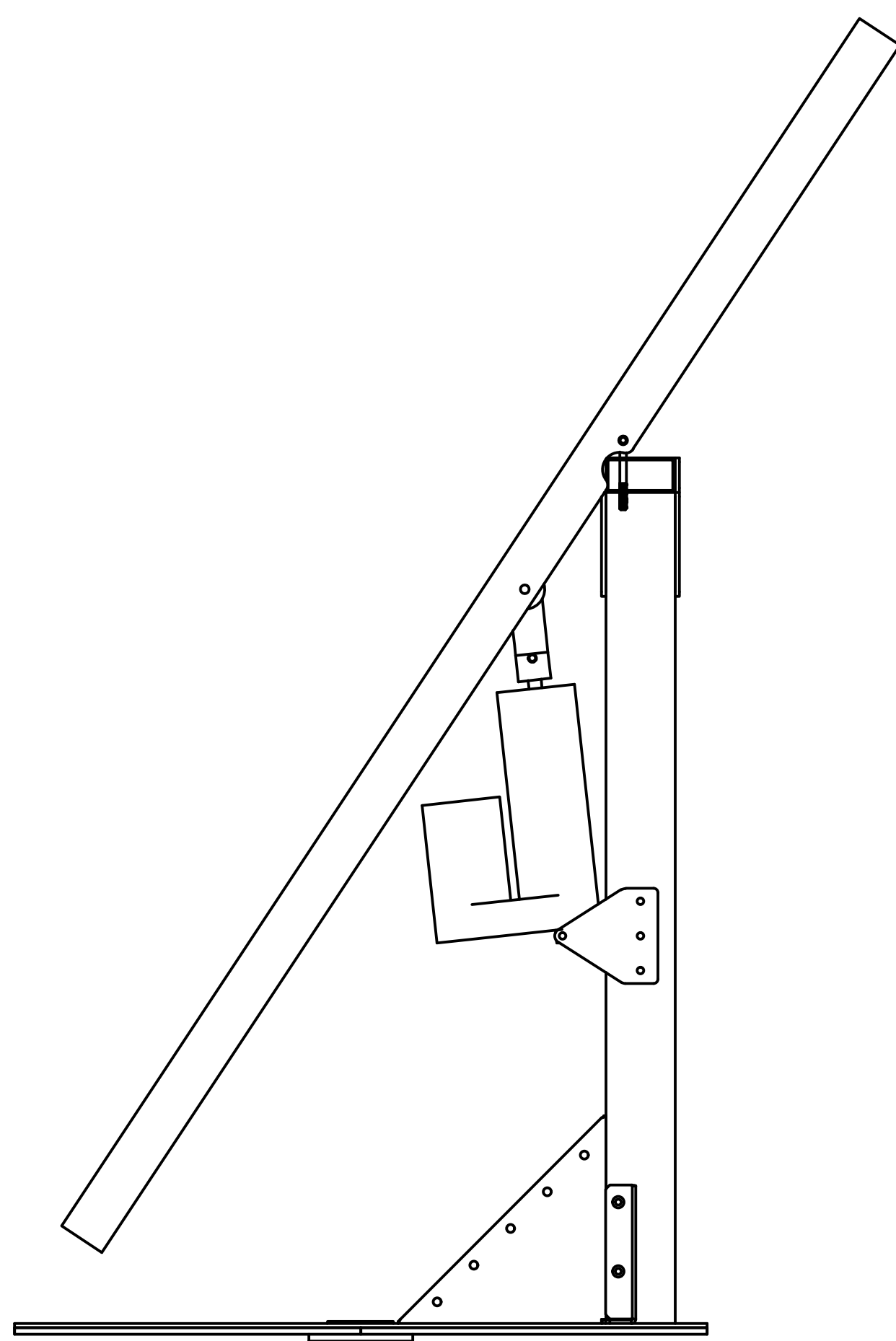
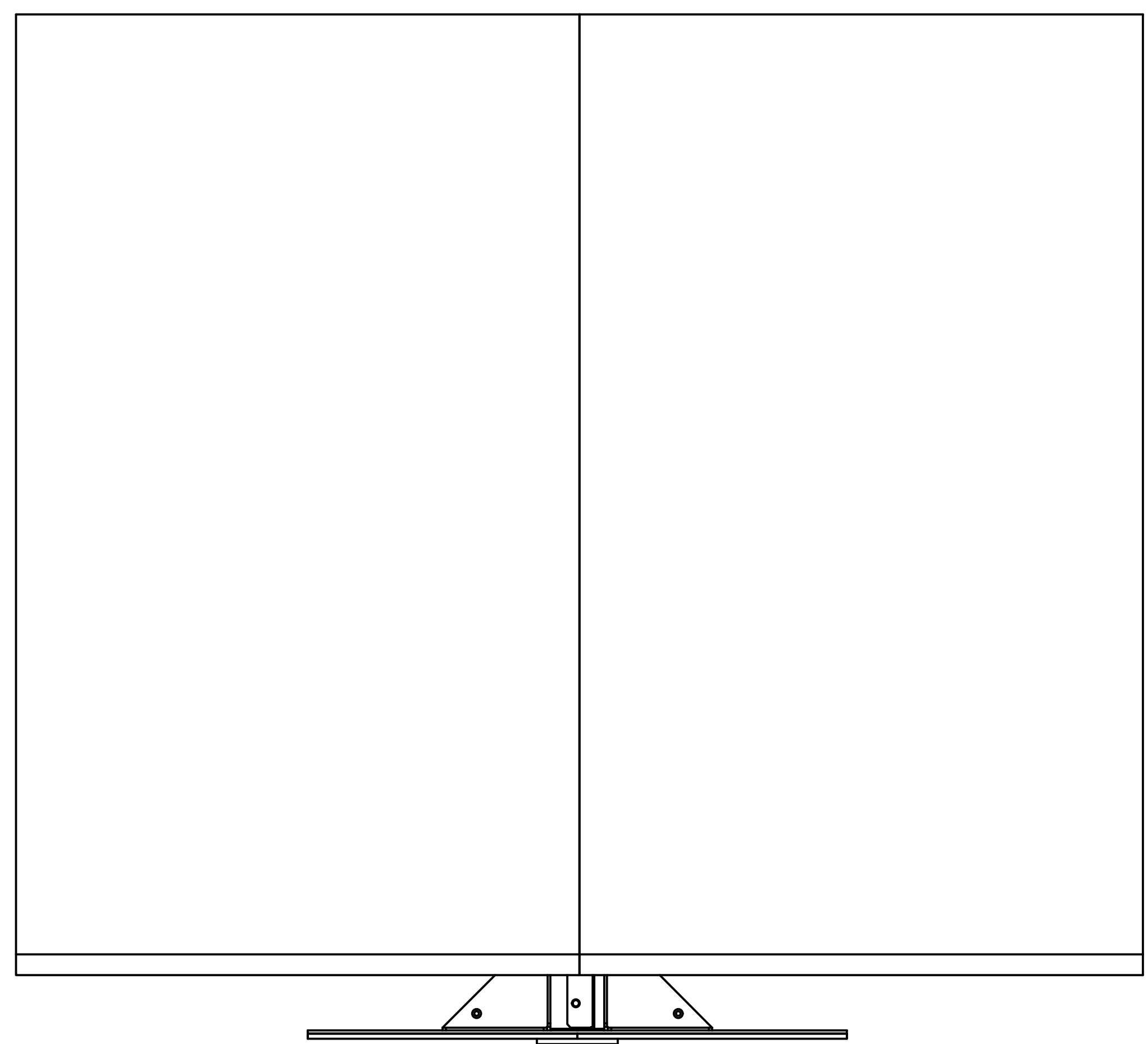
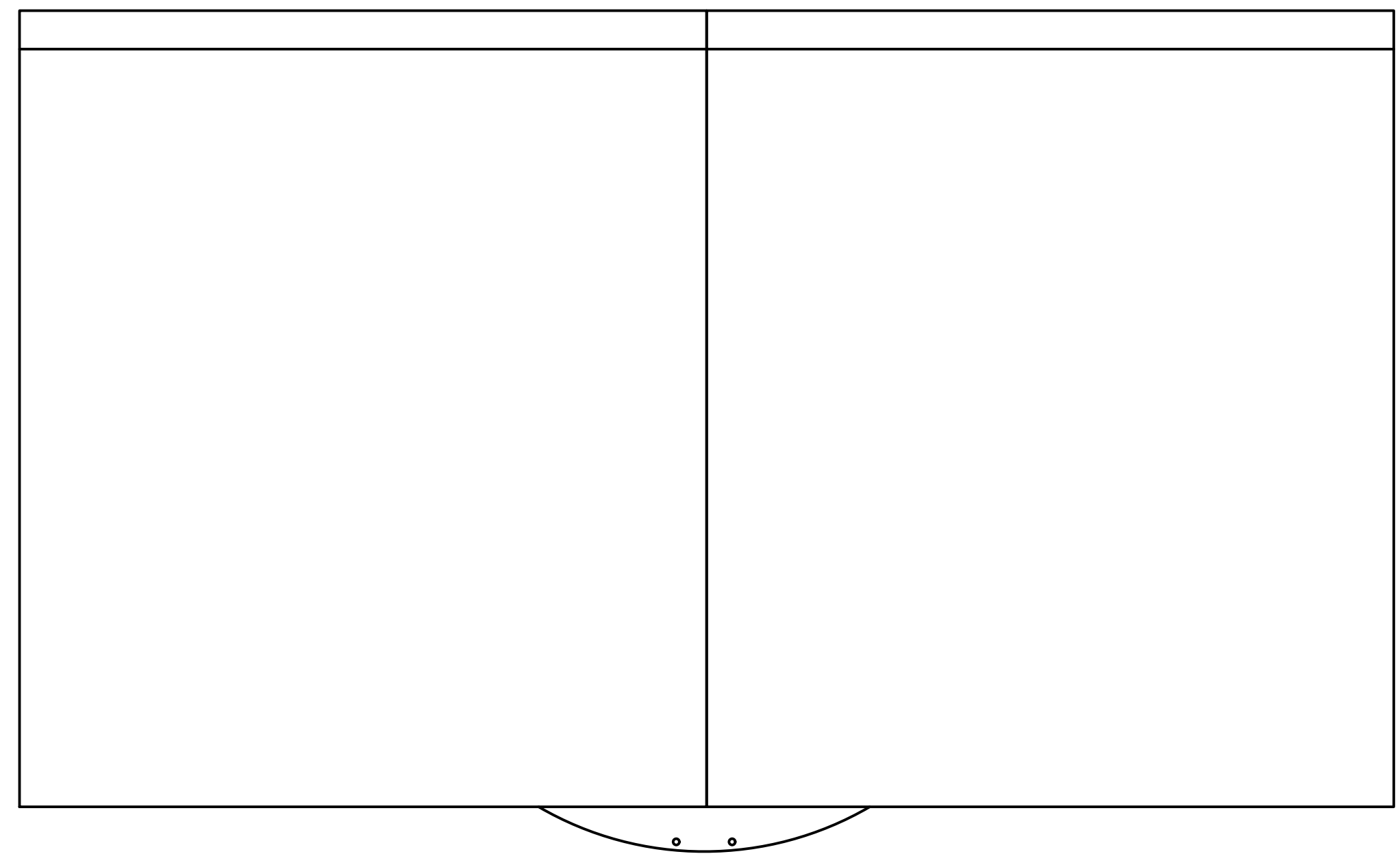

DRAWN groteh	3/8/2023	LAFAYETTE ECE DIVISION		
CHECKED cironer		TITLE		
QA		TURRET ASSEMBLY INSTRUCTIONS		
MFG		SIZE D	DWG NO 24	REV A
APPROVED weyt		SCALE 1 / 4	SHEET 5 OF 5	

8 7 6 5 4 3 2 1