

Maintenance Manual

ECE 492 - Spring 2015

Abstract

The maintenance manual that a document that unifies and indexes all low-level documentation. Anyone required to maintain the Dynamometer system should refer back to this document.

Table of Contents

Calibration	Torque	3
	RPM	4
	Sensor	4
Maintenance	Water Cooling	5
	Dynamometer Oil	5
	Software	5
Schematic	Wiring Layout	6

Calibration

Torque Calibration



To calibrate the torque for the Dynamometer we must use the VSCADA software. There may be a more detailed report of the software steps of this process in the VSCADA maintenance manual, but a brief description of the weight set up will be provided here. The system is calibrated by hanging different sized weights to a weight holder attached to the hole in the top right corner of this picture. A table with a column to record the torque, measured in foot pounds, and another column to record the software measurement value. Since the measurements are all in foot-pounds, all attached weights must be multiplied by 1.5 because the hole is 1.5 feet from the center of the motor shaft.

First, record the strain gauge value read by the VSCADA system without any weight attached to the hole in the top right corner of this picture. This data point should serve as the y-intercept for the calibration values. Next, attach a weight stand to the hold by lining up the holes and securing it with a bolt. This stand can be found in the manufacturing lab in the mechanical engineering department on the first floor of the Acopian Engineering Center and weighs approximately 4 pounds (which equals about 6 foot-pounds of torque for this system). Finally, add increments of 10 pounds to the weight stand and record the readout values from the VSCADA software. Once we have measured at least 5 or 6 different weights

(the setup cannot handle much more than this), there should be enough data to generate a linear regression line in Excel. Note the y-intercept as an offset value and the slope as a scale factor for the torque to readout value.

RPM Calibration

The RPM calibration was done using the VSCADA software. For more detailed explanations of the software system see the VSCADA maintenance manual. This calibration was meant to synchronize the Curtis motor controller RPM reading and the Huff box RPM reading. A third manual RPM measurement was made using a tachometer. This measurement accurately corresponded to the Curtis reading, therefore the Huff software reading was calibrated against it. This was done by creating a table with two columns: one for Huff RPM and one for Curtis RPM. The throttle and load input was varied to generate different RPM values. After 10 to 15 different data points were recorded, a linear regression line was generated for the data with the Curtis RPM as the independent variable (y) and the Huff RPM as the dependent variable (x). The equation used was $-4.499X + 9402.315$ with an R^2 value of .99. This R^2 proved that this linear trend was valid, and the equation was implemented in the VSCADA software as a correction factor to yield the correct Huff RPM readings.

Sensor Calibration

All sensor calibration can be found in the Dynamometer Calibration and Maintenance Manual. Depending on the sensor the data may be calibrated by the electrical system or can be altered in post by the VSCADA system. As of 5/12/2015 all sensors have been accurately calibrated.

Maintenance

Water Cooling System Maintenance

In its current state the water cooling system is not maintainable. The water reservoir can not be emptied without removing the entire motor controller stand from the dynamometer. This issue must be addressed next year. A possible solution to consider is to move the main water basin off the dynamometer. This will let the water be changed more easily as well as air would be able to escape the system.

Dynamometer Oil Maintenance

The oil in the dynamometer does not need to be changed or replaced unless there is a spill. In the case of a spill there is oil absorbent located in AEC 402. After consulting an advisor proceed to apply the adsorbent followed by a clean up of the room when the oil has been absorbed.

Once the new oil has arrived to replace the oil you must get the oil pump from the mechanical engineering workshop. They will instruct you on how to use this to refill the dynamometer with oil.

Software Maintenance

All software maintenance information can be find in the VSCADA maintenance manual.

Dyno Schematic

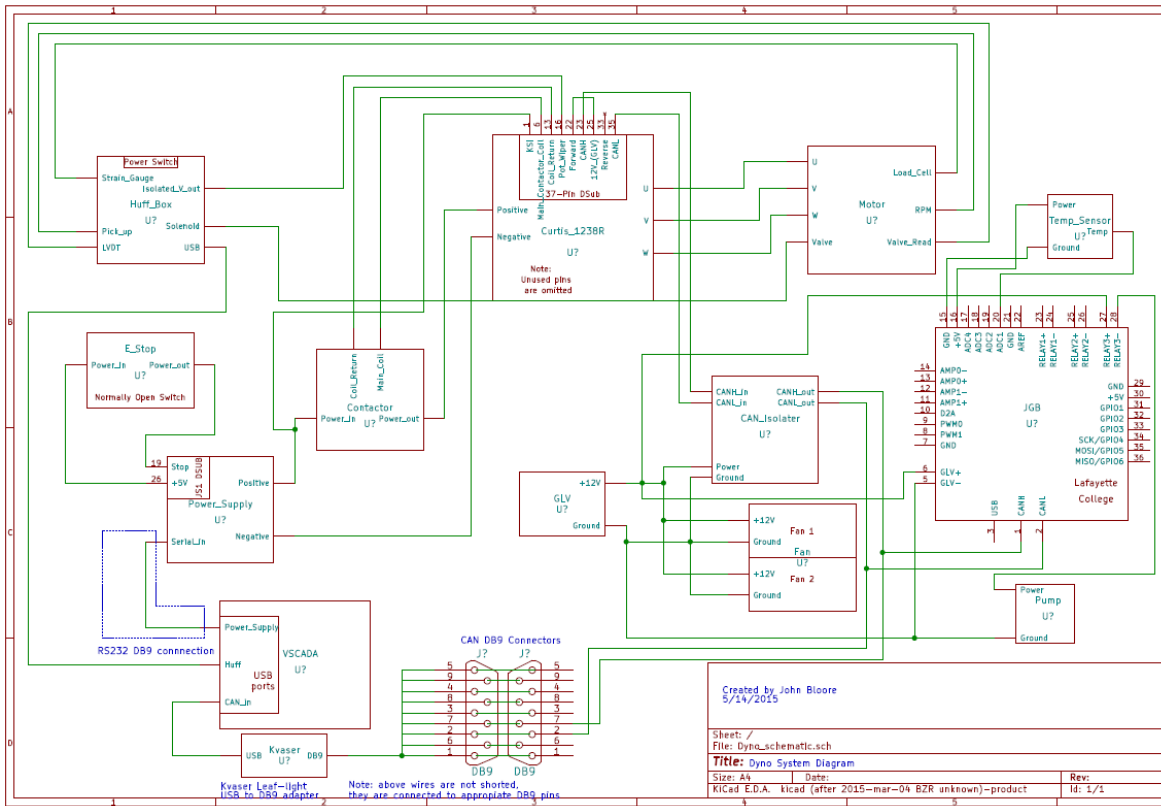

Note: the GLV block is replaced by a 12V battery in the current set up.