

# Acceptance Test Plan

ECE 492 – Spring 2014

Latest Revision: 8 May 2014

Prepared by: Drew Jeffrey

## Abstract

The Acceptance Test Plan (ATP) defines the necessary test procedures to be used in order to verify all functional requirements and specifications for the integrated Lafayette Formula Electric Vehicle (LFEV-2014) system are met. Each requirement can be proven to be met through analysis, test, and/or inspection where appropriate. A list of additional documents used to verify the system as well as the full list of deliverables is included in this document.

# Table of Contents

|  |           |
|--|-----------|
| <b>EXECUTIVE SUMMARY</b>                                   | <b>4</b>  |
| INTRODUCTION   | 4         |
| SAFETY   | 4         |
| PRECONDITIONS  | 4         |
| <b>DELIVERABLES</b>  | <b>5</b>  |
| <b>TEST PROCEDURES</b>                                     | <b>6</b>  |
| TEST CONFIGURATIONS  | 6         |
| CONFIGURATION A  | 6         |
| CONFIGURATION B  | 7         |
| CONFIGURATION C  | 8         |
| CONFIGURATION D  | 9         |
| <b>T000: BATTERY PACK DISPLAY AND SAFETY QUALIFICATION</b> | <b>10</b> |
| <b>T001: LOW CURRENT DISCHARGE TEST</b>                    | <b>14</b> |
| <b>T002: CHARGE CYCLE TEST</b>                             | <b>17</b> |
| <b>T003: DROP-OUT CHARGE TEST</b>                          | <b>21</b> |
| <b>T004: HIGH CURRENT DISCHARGE TEST</b>                   | <b>25</b> |
| <b>T005: RS-485 COMMUNICATION WITH OFF-BOARD SYSTEMS</b>   | <b>27</b> |
| <b>T006: MCS AND TEST STAND VERIFICATION</b>               | <b>29</b> |
| <b>T007: RELIABILITY TEST</b>                              | <b>32</b> |
| <b>T008: MAINTAINABILITY TEST</b>                          | <b>34</b> |
| <b>APPENDIX A: TRACEABILITY MATRIX</b>                     | <b>36</b> |

---

|  |                  |
|--|------------------|
| <b><u>APPENDIX B – ANALYSIS REQUIREMENTS</u></b> | <b><u>46</u></b> |
| <b><u>APPENDIX C – INSPECTION GUIDE</u></b>      | <b><u>50</u></b> |
| <b><u>APPENDIX D – TEST RESULTS FORM</u></b>     | <b><u>55</u></b> |

---

# Executive Summary

## Introduction

As part of a complex system where performance and safety are of primary importance, the Lafayette Formula Electric Vehicle – Energy Storage, Control, and Management (LFEV-ESCM) system must be shown to meet acceptance criteria. These criteria, enumerated below, address the functionality of the overall system and, where applicable, individual subsystems. Our system consists of a self-contained battery pack and charger system which monitors cell voltages and will use an internal cell balancing algorithm to automatically charge the pack efficiently.

## Safety

All tests must follow the safety procedures outlined in the LFEV-ESCM Safety Plan. Any additional safety procedures not listed in the safety plan will be listed before the test procedure.

## Preconditions

The initial state in which the system should be configured will be listed before the test procedure.

# Deliverables

The following items are expected to be delivered as part of successful completion of this project.

| Item  | Description and URL (if applicable)       | P/F | Date | Signature |
|---|---|-----|------|-----------|
| <b>List of Deliverables (from LFEV-Y2-2014 Statement of Work)</b> |   |     |      |           |
| <b>D000</b>   | PDR Materials                             |     |      |           |
| <b>D001</b>   | CDR Materials                             |     |      |           |
| <b>D002</b>   | User's Manual                             |     |      |           |
| <b>D003</b>   | Final Report and Maintenance Manual       |     |      |           |
| <b>D004</b>   | Acceptance Test Plan                      |     |      |           |
| <b>D005</b>   | Acceptance Test Report                    |     |      |           |
| <b>D006</b>   | QA Audit Report                           |     |      |           |
| <b>D007</b>   | Project Website                           |     |      |           |
| <b>D008</b>   | LFEV-Y2-2014 Integrated System            |     |      |           |
| <b>D009</b>   | Conference Paper, Presentation, and Video |     |      |           |
| <b>D010</b>   | Project Poster                            |     |      |           |
| <b>D011</b>   | Calibration and Accuracy Analysis         |     |      |           |
| <b>D012</b>   | Software Maintainability Plan             |     |      |           |
| <b>D013</b>   | Request for Non-Budget Funding            |     |      |           |
|   | <b>Additional Documents</b>               |     |      |           |
| <b>D014</b>   | EMI/EMC Analysis Memo                     |     |      |           |
| <b>D015</b>   | Hazmat Analysis Memo                      |     |      |           |
| <b>D016</b>   | LFEV-Y2-2014 Safety Plan                  |     |      |           |
| <b>D017</b>   | Reliability Report                        |     |      |           |
| <b>D018</b>   | Maintainability Report                    |     |      |           |
| <b>D019</b>   | System Bill of Materials                  |     |      |           |
| <b>D020</b>   | LFEV-Y1-2013 Subsystem Compliance Memo    |     |      |           |
| <b>D021</b>   | Accumulator Container FEV Compliance Memo |     |      |           |
| <b>D022</b>   | GLV/HV Isolation FEV Compliance Memo      |     |      |           |
| <b>D023</b>   | TSV/AIR FEV Compliance Memo               |     |      |           |
| <b>D024</b>   | Fusing FEV Compliance Memo                |     |      |           |

# Test Procedures

## Test Configurations

Please see the Interface Control Document (ICD) for details regarding each junction on each assembly in the test setups.

### Configuration A

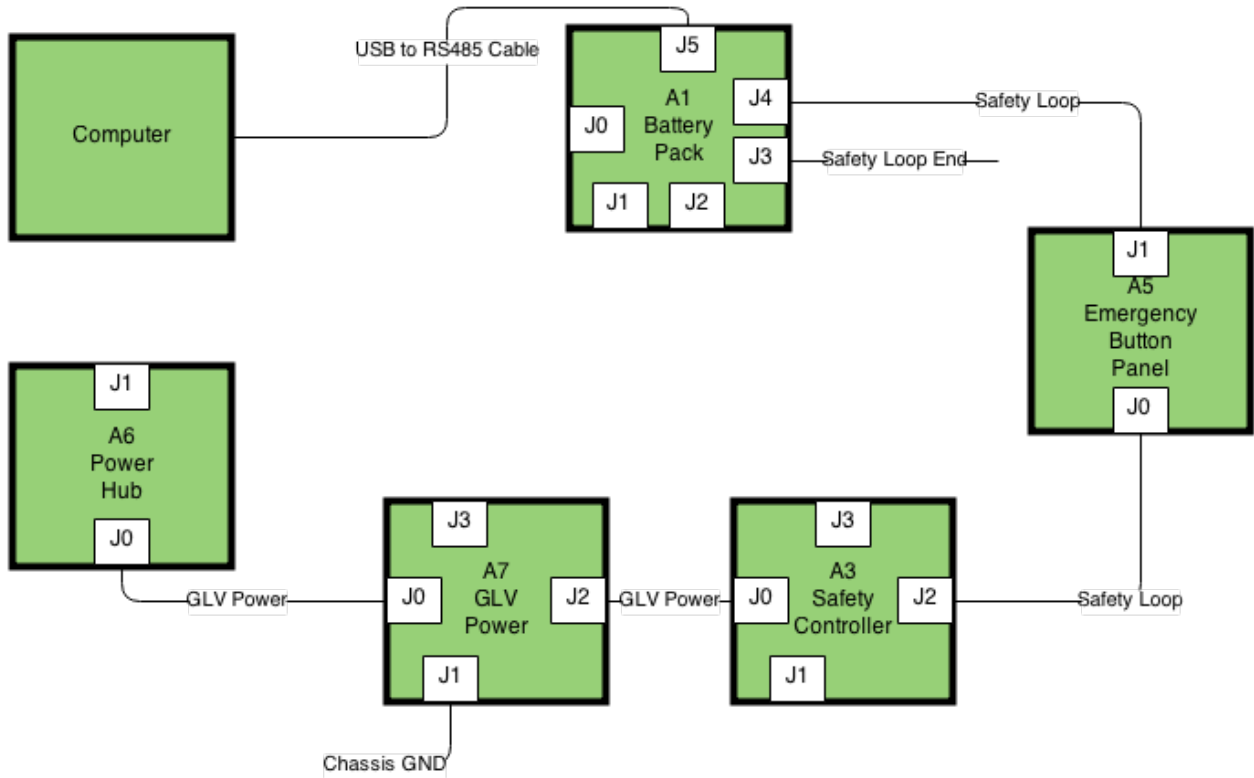

### Configuration B

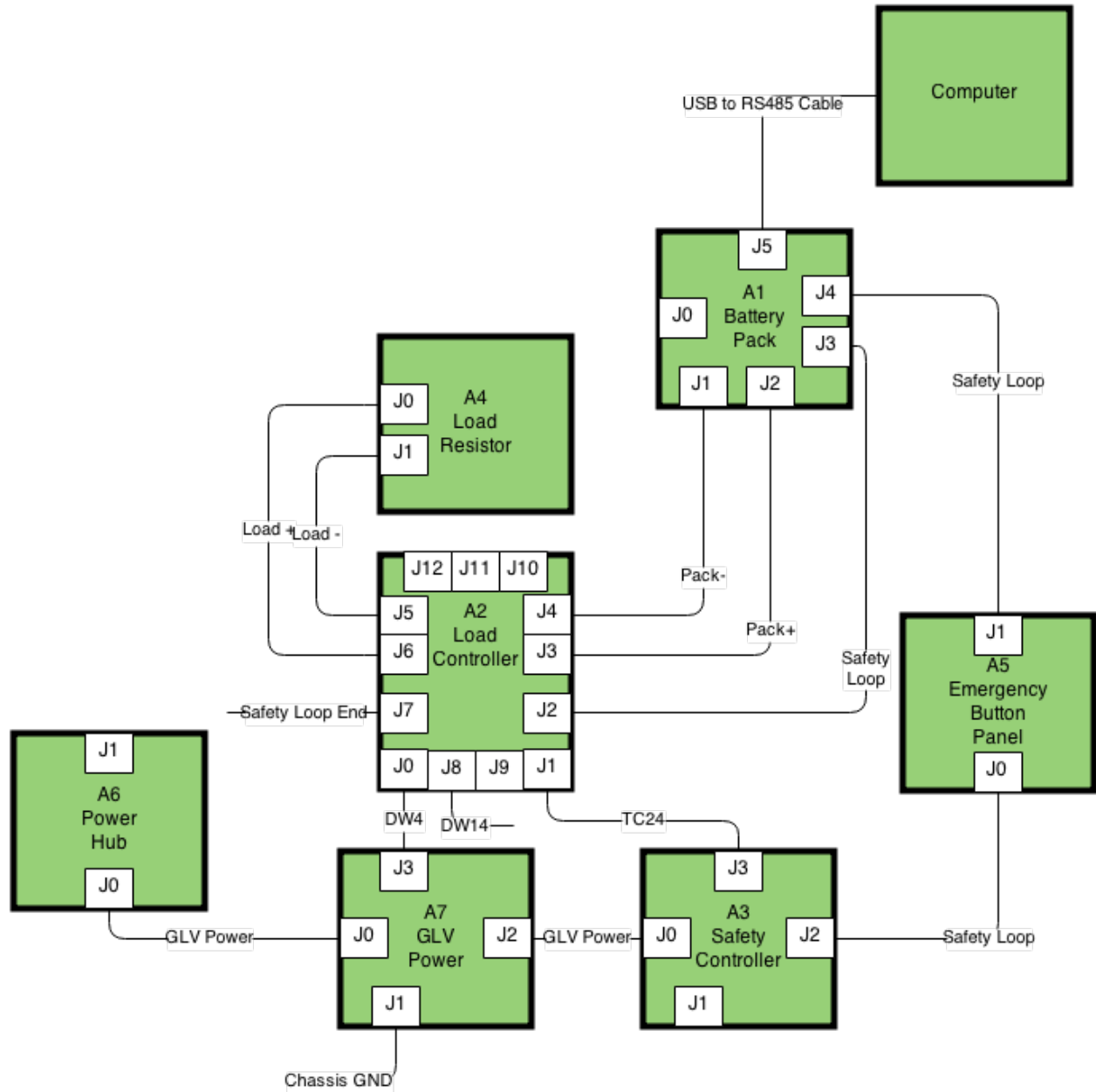

## Configuration C

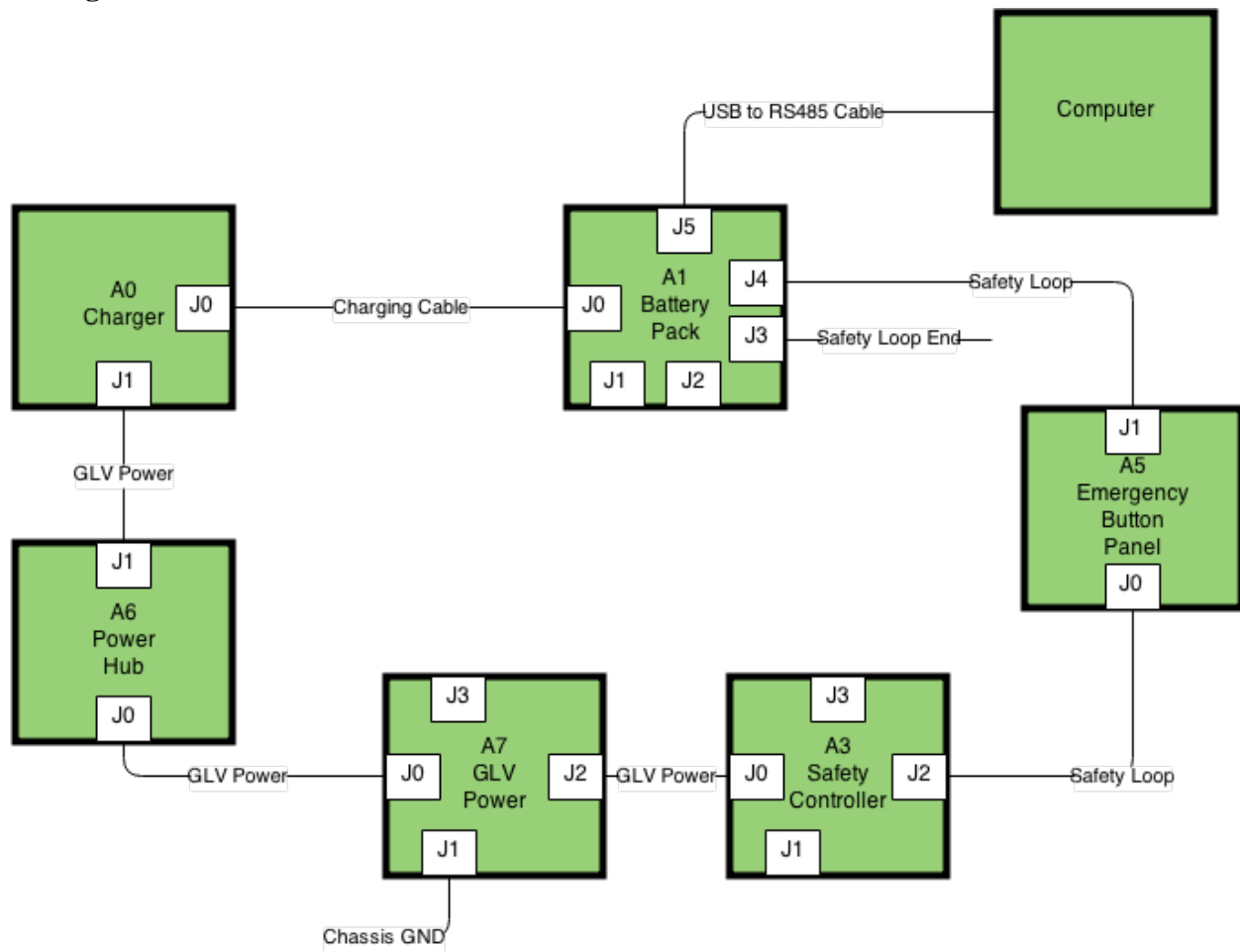



Configuration D

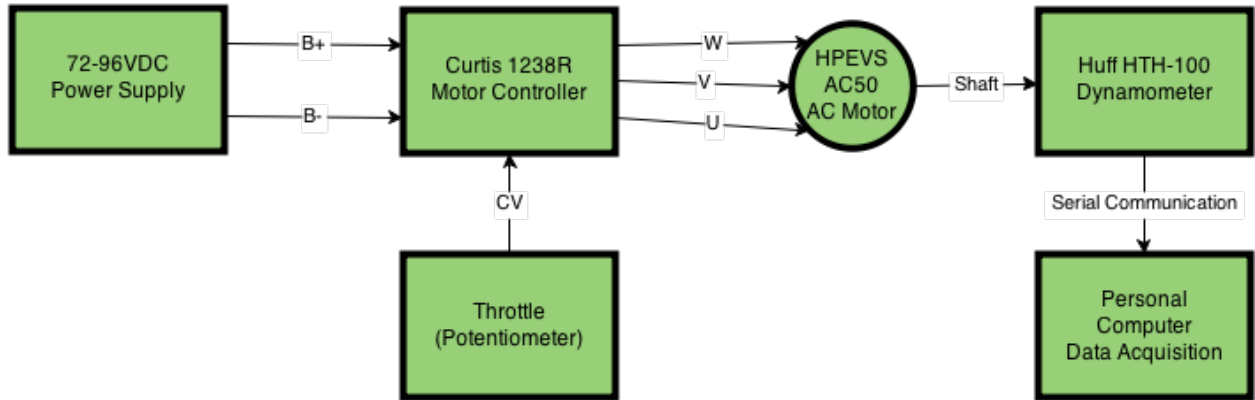

## T000: Battery Pack Display and Safety Qualification

This test ensures the battery pack meets the necessary safety guidelines before beginning discharge and charging cycle tests. The onboard watchdog and pack manager's ability to open the safety loop will be tested. In addition the RS-485 communication link will also be exercised. This test must be completed before beginning T001 - T003.

### Preconditions:

- All BMS boards and Pack Manager components are being sufficiently powered by the current state of charge of the battery pack
- System is connected in test configuration A
- System has been calibrated according to D11: Calibration and Accuracy Memo and tolerance values for all ATP measurements have been written in based on the statistical analysis found in D11.
- The USB to RS-485 adapter is plugged into a USB port of the personal computer being used for testing.
- The RS-485 adapter is connected to the battery pack's RS-485 serial port.
- RealTerm is running on the host personal computer
- All systems outside of the battery pack are powered off
- The power hub is plugged into the wall

### Test Procedure:

1. Perform tests for passing criteria 1-5
2. Press the switch on the power hub labeled "GLV" to power the GLV power system. The switch should light up to indicate it is on
3. Attach the battery pack to the safety loop and press the reset safety loop button on the safety controller box
4. Perform tests for passing criteria 6
5. Press the "reset" button on the battery pack
6. Perform test for passing criteria 7-8
7. Press the reset safety loop button on the safety controller box
8. Send Command TESTMODE 1 and followed by TWD 0 to exercise the on-board watchdog's operation during timeout
9. Perform test for passing criteria 9
10. Send command TWD 0 to return the watchdog to normal operation
11. Perform test for passing criteria 10
12. Send Command TESTMODE 1 followed by TOB 1 to fake an out of bounds sensor reading
13. Perform test for passing criteria 11



4. The measured resistance between the poles of the accumulator container and the inside wall of the pack is  $> 1M\Omega$ .

| Measured Resistance<br>(Ohms) |
|-------------------------------|
|                               |

Witness/Examiner Signature
Date
Pass/Fail

5. The measured resistance between the discharge path of the pack and following GLV components are  $> 1M\Omega$ .

| GLV Component                     | Measured Resistance<br>(Ohms) |
|-----------------------------------|-------------------------------|
| Safety Loop In Wire               |                               |
| Safety Loop +24V Wire             |                               |
| Safety Loop -24V Wire             |                               |
| Safety Loop Out Wire              |                               |
| RS-485 Serial Port Out Pin 1 (D+) |                               |
| RS-485 Serial Port Out Pin 2 (D-) |                               |

Witness/Examiner Signature
Date
Pass/Fail

6. The safety loop is closed when the Safety Loop reset button is pressed.

Witness/Examiner Signature
Date
Pass/Fail

7. The safety loop is opened when the “reset” switch is triggered on the battery pack

Witness/Examiner Signature
Date
Pass/Fail

8. TS-8160-4200's software begins automatically after the reset switch is pressed and the computer boots itself up again.

\_\_\_\_\_  
Witness/Examiner Signature

\_\_\_\_\_  
Date

\_\_\_\_\_  
Pass/Fail

9. The safety loop is opened when the TWD 0 command is sent to the pack manager and the watchdog timer times out.

\_\_\_\_\_  
Witness/Examiner Signature

\_\_\_\_\_  
Date

\_\_\_\_\_  
Pass/Fail

10. The safety loop closes when TWD 1 is sent to the pack manager and the safety loop reset button is pressed.

\_\_\_\_\_  
Witness/Examiner Signature

\_\_\_\_\_  
Date

\_\_\_\_\_  
Pass/Fail

11. The safety loop is opened when the TOB 1 command is sent to the pack manager to simulate an out of bounds reading.

\_\_\_\_\_  
Witness/Examiner Signature

\_\_\_\_\_  
Date

\_\_\_\_\_  
Pass/Fail

## T001: Low Current Discharge Test

This test will simulate a discharge cycle of the battery pack and exercise the safety features of the pack which will be utilized when the voltage in the pack reaches critical levels.

### Preconditions:

- All BMS boards and Pack Manager components are being sufficiently powered by the current state of charge of the battery pack
- The pack manager's test mode is off
- System is connected in test configuration B
- All systems outside of the battery pack are powered off
- The power hub is plugged into the wall
- Test T000 must have been performed and passed. If this has not been passed, the instructor's explicit approval must be given to perform this test.

### Test Procedure:

1. Perform test for Passing Criterion 1 by attempting to decouple the Powerlock connectors from each side of the pack.
2. Perform tests for passing criteria 2.
3. Press the switch on the power hub labeled "GLV" to power the GLV power system. The switch should light up to indicate it is on.
4. Ensure that all safety systems are enabled and press the "reset safety loop" button
5. Perform test for passing criteria 3
6. Close the load controller relays to connect the battery pack HV terminals to the resistive load.
7. Depress the button labeled "200 A" on the Load. Adjust the coarse adjustment knob (larger knob) on the dial labeled "Load Adjust" until the LED on the Load indicates that 60 A are being drawn by the load.
8. Perform tests for passing criteria 4-5
9. Wait for the safety loop to become opened by the pack manager when the lower voltage bound of the pack reaches its configured value or the pack manager system shuts down due to lack of sufficient voltage. This ensures a fully discharged cell
10. Perform tests for passing criteria 6-7



5. The pack manager's LCD display shows the system is in discharge mode.

\_\_\_\_\_  
Witness/Examiner Signature                      Date                      Pass/Fail

6. The safety loop is opened by the pack manager when a cell voltage reaches the low voltage threshold.

\_\_\_\_\_  
Witness/Examiner Signature                      Date                      Pass/Fail

7. The TS-8160-4200's power LED is still lit when it opens the safety loop to end the discharge cycle.

\_\_\_\_\_  
Witness/Examiner Signature                      Date                      Pass/Fail



## T002: Charge Cycle Test

This test will simulate a charge cycle of the battery pack and exercise its “plug and forget” features.

### Preconditions:

- All BMS boards and Pack Manager components are being sufficiently powered by the current state of charge of the battery pack
- The pack manager’s test mode is off
- System is connected in test configuration C, with the charging cable unconnected from the battery pack
- All systems outside of the battery pack are powered off
- The charger is plugged into the wall and is powered on
- Test T000 must have been performed and passed. If this has not been passed, the instructor’s explicit approval must be given to perform this test.
- T001 was recently completed or the battery pack’s state of charge is less than 10% of the full charge

### Test Procedure:

1. Press the switch on the power hub labeled “GLV” to power the GLV power system. The switch should light up to indicate it is on.
2. Ensure that all safety systems are enabled and press the “reset safety loop” button
3. Perform tests for passing criterion 1.
4. Remove the dummy plug from the charging port and plug the charging cable into the charging port on the battery pack
5. Perform tests for passing criteria 2-4.
6. Press the reset safety loop button
7. Perform tests for passing criteria 5
8. Wait for the pack manager to state charging has completed
9. Perform tests for passing criteria 6-10
10. Press the reset safety loop button
11. Perform tests for passing criteria 11-12
12. Disconnect the charging cable from the battery pack
13. Plug the dummy plug into the charging port and then press the reset safety loop button
14. Perform tests for passing criteria 13

Date of Test: \_\_\_\_\_ Time of Test: \_\_\_\_\_

Person Performing Test: \_\_\_\_\_

ECE Professor Witnessing Test: \_\_\_\_\_

**Passing Criteria**

1. Safety Loop is closed before the charging cable is plugged into the battery pack and the “dummy” plug is removed from the charging port.

\_\_\_\_\_  
Witness/Examiner Signature                      Date                      Pass/Fail

2. Safety Loop is opened when the “dummy” plug is removed from the battery pack and the charging cable is plugged into the battery pack.

\_\_\_\_\_  
Witness/Examiner Signature                      Date                      Pass/Fail

3. The pack manager enters the charging state when the charging cable is plugged into the battery pack by displaying a status message that the pack is charging on the LCD screen.

\_\_\_\_\_  
Witness/Examiner Signature                      Date                      Pass/Fail

4. The charging relays are closed automatically by the pack manager to allow the battery to begin charging as shown by the drawn current on the power supply.

\_\_\_\_\_  
Witness/Examiner Signature                      Date                      Pass/Fail

5. Safety Loop does not close when the reset safety loop button is pressed during the charging cycle.

\_\_\_\_\_  
 Witness/Examiner Signature                      Date                      Pass/Fail

6. No error messages or system failures related to charging were encountered during the charge cycle.

\_\_\_\_\_  
 Witness/Examiner Signature                      Date                      Pass/Fail

7. The time to complete the charge cycle is within  $\pm 0.5$  hours of the estimated time of charge based on beginning SOC reported by the pack manager.

| Initial SOC (%) | Charging Current (A) | Estimated Time to Charge (Hrs) | Actual Time of Charge (Hrs) | Error |
|-----------------|----------------------|--------------------------------|-----------------------------|-------|
|                 |                      |                                |                             |       |

\_\_\_\_\_  
 Witness/Examiner Signature                      Date                      Pass/Fail

8. The LCD screen on the battery pack display a status message indicating charging has completed successfully.

\_\_\_\_\_  
 Witness/Examiner Signature                      Date                      Pass/Fail

9. The LCD screen displays an SOC of  $100 \pm$  \_\_\_\_\_% when the pack manager indicates the battery pack is fully charged

\_\_\_\_\_  
 Witness/Examiner Signature                      Date                      Pass/Fail

10. The charge relays are opened automatically when the pack manager indicates the battery pack is fully charged.

\_\_\_\_\_  
Witness/Examiner Signature                      Date                      Pass/Fail

11. Safety Loop does not close when the reset safety loop button is pressed after the charging cycle has completed but before the charger cable has been removed from the battery pack.

\_\_\_\_\_  
Witness/Examiner Signature                      Date                      Pass/Fail

12. Pack manager enters shows that it enters the discharging state after charging completes

\_\_\_\_\_  
Witness/Examiner Signature                      Date                      Pass/Fail

13. Safety Loop is closed after the charging cable is removed from the battery pack, the “dummy” charge plug is inserted into the charging port, and the reset safety loop button is pressed.

\_\_\_\_\_  
Witness/Examiner Signature                      Date                      Pass/Fail

## T003: Drop-Out Charge Test

This test will simulate a discharge cycle of the battery pack in which the total voltage of the pack becomes too low to power the pack manager and BMS boards. It will then exercise the recovery of the system when the charger is plugged into the system to return it to an operational state.

### Preconditions:

- All BMS boards and Pack Manager components are being sufficiently powered by the current state of charge of the battery pack
- The pack manager's test mode is off
- System is connected in test configuration C
- All systems outside of the battery pack are powered off
- The power hub is plugged into the wall
- Test T000 must have been performed and passed. If these have not been passed, the instructor's explicit approval must be given to perform this test.

### Test Procedure:

1. Remove the Pack Positive screw terminal wire from the Pack Manager and safely stow it such that it will not touch any other exposed wires or the discharge path of the battery pack.
2. Perform tests for passing criteria 1
3. Plug the charger into the charging port on the battery pack
4. Turn the power to charger on, set the voltage of its output to 25V, and turn the charger output on manually.
5. Press and hold the charge relay override button on the battery pack
6. Perform tests for passing criteria 2-4
7. Wait for the pack manager to state charging has completed
8. Perform tests for passing criteria 5-9
9. Disconnect the charging cable from the battery pack
10. Press the safety reset button
11. Perform tests for passing criteria 10

Date of Test: \_\_\_\_\_ Time of Test: \_\_\_\_\_

Person Performing Test: \_\_\_\_\_

ECE Professor Witnessing Test: \_\_\_\_\_

**Passing Criteria:**

1. The TS-8160-4200's green power LED becomes unlit when the pack voltage is removed from the pack manager.

\_\_\_\_\_  
Witness/Examiner Signature                      Date                      Pass/Fail

2. The TS-8160-4200's green power LED becomes lit when the charger is plugged into the battery pack and its output is turned on.

\_\_\_\_\_  
Witness/Examiner Signature                      Date                      Pass/Fail

3. The pack manager's software begins automatically and is not corrupted after the charger is plugged into the battery pack, its output is turned on, and the charge relay override button is held in.

\_\_\_\_\_  
Witness/Examiner Signature                      Date                      Pass/Fail

4. The character LCD screen displays pack information (SOC, Pack Voltage, Pack Current) within 10 seconds after plugging the charger into the battery pack, turning on its output, and holding in the charge relay override button.

| Time to Display Information(S) |
|--------------------------------|
|                                |

\_\_\_\_\_  
Witness/Examiner Signature                      Date                      Pass/Fail

5. No error messages or system failures relevant to charging were encountered during the charge cycle.

\_\_\_\_\_  
Witness/Examiner Signature                      Date                      Pass/Fail

6. The LCD screen on the battery pack display a status message indicating charging has completed successfully.

\_\_\_\_\_  
Witness/Examiner Signature                      Date                      Pass/Fail

7. The LCD screen displays a SOC of  $100 \pm \text{_____}\%$  when the pack manager indicates the battery pack is fully charged.

\_\_\_\_\_  
Witness/Examiner Signature                      Date                      Pass/Fail

8. The charging relays are opened by the pack manager when charging completes as indicated by the current draw on the power supply.

\_\_\_\_\_  
Witness/Examiner Signature                      Date                      Pass/Fail

9. Pack manager enters shows that it enters the discharging state after charging completes.

\_\_\_\_\_  
Witness/Examiner Signature                      Date                      Pass/Fail

10. Safety Loop is closed after the charging cable is removed from the battery pack, the “dummy” plug is inserted into the pack, and the reset safety loop button is pressed.

\_\_\_\_\_  
Witness/Examiner Signature                      Date                      Pass/Fail



## T004: High Current Discharge Test

This test will simulate a discharge cycle of the battery pack under the maximum current load and exercise the safety features of the pack which will be utilized when the voltage in the pack reaches critical levels.

### Preconditions:

- All BMS boards and Pack Manager components are being sufficiently powered by the current state of charge of the battery pack
- The pack manager's test mode is off
- System is connected in test configuration B
- All systems outside of the battery pack are powered off
- The power hub is plugged into the wall
- Test T000 and T001 must have been performed and passed. If this has not been passed, the instructor's explicit approval must be given to perform this test.

### Test Procedure:

1. Press the switch on the power hub labeled "GLV" to power the GLV power system. The switch should light up to indicate it is on.
2. Ensure that all safety systems are enabled and press the "reset safety loop" button
3. Perform test for passing criteria 1
4. Close the load controller relays to connect the battery pack HV terminals to the resistive load.
5. Depress the button labeled "200 A" on the Load. Adjust the coarse adjustment knob (larger knob) on the dial labeled "Load Adjust" until the LED on the Load indicates that 200 A are being drawn by the load.
6. Perform tests for passing criteria 2
7. Wait for the safety loop to become opened by the pack manager when the lower voltage bound of the pack reaches its configured value or the pack manager system shuts down due to lack of sufficient voltage. This ensures a fully discharged cell
8. Perform tests for passing criteria 3-4

Date of Test: \_\_\_\_\_ Time of Test: \_\_\_\_\_

Person Performing Test: \_\_\_\_\_

ECE Professor Witnessing Test: \_\_\_\_\_

**Passing Criteria**

- The safety loop is closed when the “reset safety loop” button is pressed.

\_\_\_\_\_

Witness/Examiner Signature
Date
Pass/Fail

- The discharge current displayed on the LCD screen of the battery pack is within  $\pm$  \_\_\_\_\_% of the drawn current displayed on the load resistor unit.

| Load Resistor<br>Displayed Current (A) | LCD Displayed<br>Current (A) | % Error |
|--|------------------------------|---------|
|  |                              |         |

\_\_\_\_\_

Witness/Examiner Signature
Date
Pass/Fail

- The discharge fuse remains intact and not blown during the entire high current discharge cycle.

\_\_\_\_\_

Witness/Examiner Signature
Date
Pass/Fail

- The safety loop is opened by the pack manager when a cell voltage reaches the low voltage threshold

\_\_\_\_\_

Witness/Examiner Signature
Date
Pass/Fail

## **T005: RS-485 Communication with Off-Board Systems**

This test verifies correct operation of the Pack Management System's software in being able to receive messages via RS-485 and supply the requested battery details to the requesting system.

### **Preconditions:**

- All BMS boards and Pack Manager components are being sufficiently powered by the current state of charge of the battery pack
- The pack manager's test mode is off
- The USB to RS-485 adapter is plugged into a USB port of the personal computer being used for testing.
- The RS-485 adapter is connected to the battery pack's RS-485 serial port.
- RealTerm is running on the host personal computer

### **Test Procedure:**

1. Send command 1 TEST? To the pack manager from RealTerm
2. Perform tests for passing criteria 1
3. Send command 1 CELLCNT? To the pack manager from RealTerm
4. Perform tests for passing criteria 2
5. Send command 1 V? to the pack manager from RealTerm.
6. Perform tests for passing criteria 3
7. Send command 2 TEST? to the pack manager from RealTerm to send a command with a mismatched address.
8. Perform tests for passing criteria 4

Date of Test: \_\_\_\_\_ Time of Test: \_\_\_\_\_

Person Performing Test: \_\_\_\_\_

ECE Professor Witnessing Test: \_\_\_\_\_

**Passing Criteria:**

1. The pack manager's returns the value 0x42 to RealTerm upon sending the command 1 TEST?.

| Expected Value | Returned Value |
|----------------|----------------|
| 0x42           |                |

\_\_\_\_\_
\_\_\_\_\_
\_\_\_\_\_

Witness/Examiner Signature
Date
Pass/Fail

2. The pack manager returns to RealTerm 7 as the number of cells when the command 1 CELLCNT? is sent.

| Expected Value | Returned Value |
|----------------|----------------|
|                |                |

\_\_\_\_\_
\_\_\_\_\_
\_\_\_\_\_

Witness/Examiner Signature
Date
Pass/Fail

3. The pack manager returns to RealTerm 7 voltage measurements when the command 1 V? is sent.

\_\_\_\_\_
\_\_\_\_\_
\_\_\_\_\_

Witness/Examiner Signature
Date
Pass/Fail

4. The pack manager does not return any information to RealTerm when it receives a command addressed to a different pack manager board

\_\_\_\_\_
\_\_\_\_\_
\_\_\_\_\_

Witness/Examiner Signature
Date
Pass/Fail

## T006: MCS and Test Stand Verification

This test will verify correct operation of motor while connected to a dynamometer on a test bench. It will verify that the motor, motor controller and dynamometer are all functional and can be utilized by future LFEV teams in the complete Formula vehicle.

### Preconditions:

- Motor Proposal must be approved and MCS/Test Stand components have arrived. If unable to get motor approval or delivery by the system delivery date, this test will not be conducted.
- Motor and dynamometer are securely mounted to test bench.
- Motor and dynamometer are connected to each other and the system is connected in configuration D.
- Motor is connected to motor controller and the motor controller is plugged into a power supply capable of supplying  $>72VD$
- Area is prepared for safe operation of motor according to LFEV Safety Plan.

### Test Procedure:

1. Perform tests for passing criteria 1
2. Turn on power supply to motor controller and set the power supply to 72VDC.
3. Set-up any necessary configuration parameters on motor controller.
4. Apply acceleration signal as specified in the passing criteria to motor and observe motor operation.
5. Perform tests for passing criteria 2-5
6. Remove acceleration signal to motor and wait for motor to cease rotation
7. Perform tests for passing criteria 6
8. Turn off power supply and unhook power supply from motor controller.

**Passing Criteria:**

1. Testing area and setup are confirmed to be safe for future testing and general operation of rotating machinery as defined by the LFEV-14 Safety Plan.

\_\_\_\_\_  
Witness/Examiner Signature                      Date                      Pass/Fail

2. Motor properly operates without any load attached under a low acceleration signal; demonstrates proper operation of both the motor and controller

\_\_\_\_\_  
Witness/Examiner Signature                      Date                      Pass/Fail

3. Motor spins in a controlled fashion after additional acceleration is applied through the motor controller. Motor remains securely attached to test bench and motor spins at constant RPMs when a constant signal is applied across the entire acceleration signal input range.

\_\_\_\_\_  
Witness/Examiner Signature                      Date                      Pass/Fail

4. Motor controller operates properly between its voltage range between 72 and 96 VDC; demonstrated by properly controlling the motor from within the power supply range.

\_\_\_\_\_  
Witness/Examiner Signature                      Date                      Pass/Fail

5. Dynamometer displays readings from the motor test as defined by the power graphs from the manufacturer's website.

\_\_\_\_\_  
Witness/Examiner Signature                      Date                      Pass/Fail

6. Motor stops spinning within 120 seconds when acceleration signal is removed.

|                         |
|-------------------------|
| <b>Time to Stop (S)</b> |
|                         |

\_\_\_\_\_  
Witness/Examiner Signature                      Date                      Pass/Fail

## T007: Reliability Test

This test verifies that the system can run without obvious failure for 24 hours. Combining analysis with this test will prove that our system meets reliability specifications.

### Preconditions:

- All BMS boards and Pack Manager components are being sufficiently powered by the current state of charge of the battery pack
- The pack manager's test mode is off
- System is connected in test configuration B
- All systems outside of the battery pack are powered off
- The power hub is plugged into the wall
- Tests T000-T002 have been performed and passed. If these have not been passed, the instructor's explicit approval must be given to perform this test.
- Per safety regulations, at least two qualified individuals must monitor the system at all times. For further information, see the Safety Plan.

### Test Procedure:

1. Perform the test for passing criteria 1.
2. Press the switch on the power hub labeled "GLV" to power the GLV power system. The switch should light up to indicate it is on.
3. Ensure that all safety systems are enabled and press the "reset safety loop" button
4. Begin discharging the battery pack as specified in T001 steps 6-7
5. Wait for the battery pack to finish its discharge cycle as specified in T001 step 9.
6. Power off all systems and connect the system into configuration C.
7. Charge the battery pack as specified in T002 steps 1-2, 4, and 8.
8. Wait for 24 hours from the start of T007 to complete.
9. Perform the tests for Passing Criteria 2-3.



**Passing Criteria:**

1. Testing area and setup are confirmed to be safe for future testing as defined by the LFEV-14 Safety Plan.

\_\_\_\_\_  
Witness/Examiner Signature                      Date                      Pass/Fail

2. At least two qualified individuals were present at all times and monitored the system over the entire 24 hour test period.

\_\_\_\_\_  
Witness/Examiner Signature                      Date                      Pass/Fail

3. System runs through charging and discharging cycles for 24 hours without any obvious failures.

\_\_\_\_\_  
Witness/Examiner Signature                      Date                      Pass/Fail

## **T008: Maintainability Test**

This test verifies that a novice user can perform basic maintenance on the system using the user's manual. The ability for an expert user to fix an unlikely error in the system will also be tested.

### **Preconditions:**

- All BMS boards and Pack Manager components are being sufficiently powered by the current state of charge of the battery pack
- The pack manager's test mode is off
- All systems outside of the battery pack are powered off
- The power hub is plugged into the wall
- Tests T000-T002 have been performed and passed. If these have not been passed, the instructor's explicit approval must be given to perform this test.

### **Test Procedure:**

1. Remove a charging fuse from the system to simulate a blown fuse.
2. Perform the test for passing criteria 1
3. Configure the system in order to simulate an unlikely error in the system.
4. Perform the tests for Passing Criteria 2.

**Passing Criteria:**

1. A novice user can replace a blown fuse in the system.

---

|                            |      |           |
|----------------------------|------|-----------|
| Witness/Examiner Signature | Date | Pass/Fail |
|----------------------------|------|-----------|

2. An expert user can solve an unexpected maintenance problem.

---

Problem:

---

|                            |      |           |
|----------------------------|------|-----------|
| Witness/Examiner Signature | Date | Pass/Fail |
|----------------------------|------|-----------|

# Appendix A: Traceability Matrix

These tables list each requirement by number and description. The MET column contains a letter representing how the requirement will be met.

## Key:

T = Test

D = Analysis/Simulation

I = Inspection

D, followed by a number, indicates that a separate document (ex. analysis memo) will fulfill this requirement.

| Requirement | Description  | MET              |
|-------------|--|------------------|
| <b>R000</b> | <b>Formula Hybrid Competition Rules</b>  |                  |
| R000        | The Formula Hybrid Competition rule sections relating to electrical and power subsystems of the completed car will be analyzed to determine what rules are applicable to the scope of the proposed design. All rules determined to be within the proposed scope will become constraints and requirements within the design of the integrated system in order to produce a competition ready and compliant product at the completion of the project | I                |
| <b>R001</b> | <b>VSCADA</b>  |                  |
| R001-1      | VSCADA computer hardware shall be provided as required to handle the VSCADA user interface and processing requirements. This includes on-car and off-car functions   | T000, T001, T002 |
| R001-2      | VSCADA software shall be a suite of applications built to a unified API with common data formats, protocols, look and feel. To the greatest possible extent the same core system must run on various hardware platforms in and around the LFEV components  | T000, T005       |
| R001-3      | VSCADA software must start automatically and reach a sane, operational state without human interaction   | T003             |
| R001-4      | Sudden unexpected shutdown of the VSCADA software shall not cause failure or significant data corruption   | T003             |
| R001-5      | VSCADA shall communicate with AMS by means of the I2C protocol established in 2013   | T000, T005       |
| R001-6      | A backup system or recovery strategy must be developed to all the VSCADA system to be promptly repaired after a hardware failure in less time than the MTTR given in GPR007  | D018             |
| R001-7      | VSCADA HW and SW are required to support these modes, interfaces, and displays. Charger (Plug and Forget), Discharger (Plug and Forget)  | T001, T002       |

|             |  |                              |
|-------------|--|------------------------------|
| R001-8      | All VSCADA application software must be written in conformance with a documented API using a delivered SDK   | I                            |
| R001-9      | The following analog measurands shall be monitored and stored by the VSCADA: Overall voltage, current, and power delivered to the load; Individual cell voltages; Rate of charge or discharge; estimate of battery state of charge; temperatures of ambient, all subsystems, and individual cells in the accumulator, data available from the motor controller, data available from the MCS test stand | T000, T001, T002, T005, T006 |
| R001-10     | Measure individual parameters up to 60 times a minute or at slower rates. All parameters shall have their values logged electronically along with a time stamp. Sampling rates shall be individually programmable for each measurand   | T000, T005                   |
| R001-11     | Fuel gauge displays of state of charge shall be generated  | T000, T002,                  |
| R001-12     | VSCADA software must adapt automatically and safely to different numbers of cells and packs  | T000, T005                   |
| R001-13     | All VSCADA software should automatically initialize when the VSCADA computer is powered up. It should not be necessary to manually run various programs and edit files to get the system going after a reboot or power outage  | T000, T003                   |
| R001-14     | VSCADA system shall have the capability to set alarms and shutdown rules should parameters extend beyond their predefined thresholds   | T000                         |
| <b>R002</b> | <b>VSCADA API, SDK, and Applications</b>   |                              |
| R002-1      | Scope of the API must be sufficient to support both low level debugging applications and high-level automated applications on all hardware platforms in use. Same API must be used for all applications running on or off-car  | I                            |
| R002-2      | SDK must include a complete tool chain with compilers, linkers, libraries, include files, utilities, and developer level documentation. All tools shall be actively supported and mature   | I                            |
| R002-3      | All sources must be maintained under configuration control   | I                            |
| R002-4      | The complete SDK, including API and application source under configuration control shall be delivered to or linked by the project website  | I                            |
| R002-5      | API, SDK, and applications shall be copyrighted using open source practices. The team shall identify and GPL all software written by the team  | I                            |
| R002-6      | Software written shall be maintainable as specified in GPR007  | D012, D18                    |
| <b>R003</b> | <b>Use of the 2013 Design</b>  |                              |
| R003-1      | Parts of the 2013 project that do adequately meet LFEV requirements may not be discarded and replaced with new parts that do not meet those requirements   | D020                         |
| R003-2      | The pack design must not be altered significantly, except for AMS improvement required by R004   | I                            |
| <b>R004</b> | <b>AMS Requirements</b>  |                              |
| R004-1      | Current Measurement - The AMS must measure the charge or discharge electrical current flow through each pack with accuracy sufficient for system state management, safety monitoring, and  | T001, T002                   |

|             |   |      |
|-------------|---|------|
|             | state of charge estimation  |      |
| R004-2      | Voltage Measurement - The AMS shall measure the individual cell voltages as well as measuring the total pack voltage and the total battery voltage  | T000 |
| R004-3      | Charge Algorithm - An improved charging algorithm based on a more comprehensive set of cell measurements shall be developed.  | T002 |
| R004-4      | AMS Power - The AMS must maintain regulated supply voltage to itself under all operation conditions, including high-current load and low SOC  | T001 |
| R004-5      | Measurand Calibration and Accuracy - The AMS design must be analyzed by a Calibration and Error Analysis document (D011) that states the uncertainties associated with all AMS measurands   | D011 |
| R004-6      | Cooling - The AMS requires a simple, small, manufacturable heat sink cooling system for the bypass switch. Performance of cooling system shall be proved by computer modeling and empirical measurements  | D021 |
| <b>R005</b> | <b>MCS and Test Stand Requirements</b>  |      |
| R005-1      | Motor and Controller system shall be provided to meet the requirements of the IEEE FEV competition and should be sized suitably to achieve a reasonably competitive entry   | I    |
| R005-2      | An MCS test stand shall be provided to permit the safe testing and demonstration of motor and controller performance over the operation parameters(RPM and torque profiles) implied by the IEEE FEV competition   | I    |
| R005-3      | The MCS test stand shall be instrumented with sensors that are interfaced to the VSCADA, reporting relevant performance parameters measured at the Test Stand   | I    |
| <b>R006</b> | <b>Battery Pack Requirements</b>  |      |
| R006-1      | Voltage - The system design requires a 7-cell pack, with nominal voltage of 24 VDC. The 3-cell pack design from 2013 should be extended to 7 cells  | I    |
| R006-2      | Resistance - An effort shall be made to lower the series resistance of the pack. The resistive connections in the 2013 design should be eliminated.   | D023 |
| R006-3      | Charger Interface - The charging interface shall be reliable, maintainable, and contain safety features that meet requirements. This includes an improved fusing of the charger path from the 2013 design   | I    |
| R006-4      | Diagnostics - The 2013 pack did not meet requirements related to displays and diagnostics on the pack (voltage indicators, charge state, etc). These aspects shall be corrected   | T000 |
| <b>GPR</b>  | <b>General Project Requirements</b>   |      |
| GPR001      | Documentation - Block Diagrams and schematics for all subsystems being designed will be completed using computer aided drawing programs and will be posted upon completion. Two members of the team have been designated as "Editors" and will review submitted technical memos, manuals, and drawings for accuracy, professionalism, and formatting. | I    |

|               |  |            |
|---------------|--|------------|
| GPR003        | EMI/EMC - All designs being considered for production will undergo research to determine if any components or the completed system will breach the EMI/EMC limit as specified in US CFR Title 47 Part 15 subpart B regulations for Class A digital equipment. If infractions are found, an alternative design in compliance with this requirement will be proposed before proceeding with production   | D014       |
| GPR004        | Hazmats - System designs will be analyzed for the inclusion of hazardous material before production or procurement of the hazardous substances being used. If a design includes a hazardous material and no alternative design solution is feasible, the Safety officer will update the team's safety plan and system User Manual to include specific instructions for handling these materials both in the lab and in the integrated system.  | D015       |
| GPR005        | Safety and Good Practice   | D016       |
| GPR006        | Reliability - During subsystem design, all components involved will undergo testing and/or research to determine an accurate MTBF and therefore obtain an overall MTBF for the whole system. This report will be included on the website and in the set of deliverables for CDR and final system submission.   | D017, T007 |
| GPR007        | Maintainability - Subsystem designs will be completed with the maintainability procedures in mind. A full maintenance manual for the system and MTTR reports will be submitted with the fully integrated system and to the website for reference purposes.   | D018, T008 |
| GPR008        | Manufacturability - A BOM will be provided for each subsystem at CDR. Analysis of parts on the BOM will ensure they meet tolerance standards as outlined and are available from at least two manufacturers.  | D019       |
| GPR011        | Project Demonstration - Upon complete system integration, QA, and fulfillment of the Acceptance Test Plan, a live demonstration will be presented to the ECE faculty and students. The completed battery pack and related systems will be self contained and able to operate for at least 50 days without the need of being charged, thus becoming a maintenance free display for ECE visitors.  | I          |
| GPR012        | Final disposal of project will take place the week of May 5th. System should be completed and demonstrated by this date, so final disposal is the final step to completion of the project. If adequate room is available, the battery pack can be displayed in the ECE hallway for visitors. Charger, MCS and test stand, and left over materials will be stored in AEC 402 or 400 in an orderly and inventoried fashion. All trash or disorder in AEC 400 which was a result of this project will be disposed over. | I          |
| <b>EV 1.2</b> | <b>Grounded Low Voltage and Tractive System Voltage</b>  |            |
| EV 1.2.4      | The tractive and GLV system must be galvanically isolated from one another.  | T000       |
| EV 1.2.6      | The tractive system motor(s) must be connected to the accumulator through a motor controller. Bypassing the control system and connecting the tractive system accumulator directly to the motor(s) is prohibited.  | I          |

|               |   |      |
|---------------|---|------|
| EV 1.3.1      | All Electrical insulating materials used must: (a) Be UL recognized (i.e, have an Underwriters Laboratories (www.UL.com) or equivalent rating and certification). (b) be rated for the maximum expected operating temperatures at the location of use or (c) have a minimum temperature rating of 90C. (Whichever is greater)   | I    |
| EV 1.3.2      | Vinyl electrical insulating tape and rubber-like paints and coatings are not acceptable electrical insulating materials.  | I    |
| <b>EV 3.1</b> | <b>Allowed Tractive Systems</b>   |      |
| EV 3.1.1      | The following accumulators are acceptable; batteries (e.g. lithium-ion batteries, NiMH batteries, lead acid batteries and many other rechargeable battery chemistries) and capacitors, such as super caps or ultra caps. The following accumulators are not permitted; molten salt batteries, thermal batteries, fuel cell, atomic and flywheel mechanical batteries.   | I    |
| EV 3.1.2      | Manufacturer's data sheets showing the rated specification of the accumulator cell(s) which are used must be provided in the ESF along with their number and configurations.  | I    |
| <b>EV 3.2</b> | <b>Tractive System Accumulator Container – General Requirements</b>   |      |
| EV 3.2.1      | All batteries or capacitors which store the tractive system energy must be enclosed in (an) accumulator containers  | I    |
| EV 3.2.2      | If spare accumulators are to be used then they all must be of the same size, weight and type as those that are replaced. Spare accumulator packs must be presented at Electrical Tech Inspection.   | I    |
| EV 3.2.3      | If the accumulator container(s) is not easily accessible during Electrical Tech Inspection, detailed pictures of the internals taken during assembly must be provided. If the pictures do not adequately depict the accumulator, it may be necessary to disassemble the accumulator to pass Electrical Tech Inspection.   | D021 |
| <b>EV 3.3</b> | <b>Tractive System Accumulator Container</b>  |      |
| EV 3.3.1      | If the container is made of electrically conductive material, the poles of the accumulator stack(s) and/or cells must be electrically insulated from the inside wall of the accumulator container by insulating material rated for the maximum voltage of the tractive system. All conductive surfaces on the outside of the container must have a low-resistance connection to the GLV system ground. All conductive penetrations (mounting hardware, etc.) must be located outside of the insulation and configured such that there is no possibility that they could penetrate the insulating barrier. | I    |
| EV 3.3.2      | Every accumulator container must contain at least one fuse  | I    |
| EV 3.3.3      | All batteries or capacitors that make up the accumulator must be divided into accumulator segments. Maintenance plugs, additional contactors or similar measures must be taken to allow electrical separation of the internal accumulator segments such that the separated segments contain a maximum voltage of less than 120 VDC fully charged and a maximum energy as specified in Table. This separation method must be used whenever the accumulator   | D021 |



|               |  |      |
|---------------|--|------|
|               | containers are opened for maintenance and whenever accumulator segments are removed from the container. Maintenance separation requiring tools to isolate the segments will not be accepted.   |      |
| EV 3.3.4      | If the TSV connectors of the accumulator containers can be removed without the use of tools, then a pilot contact/interlock line must be implemented which opens the shutdown circuit (see EV5.1) whenever the connector is removed.   | T001 |
| EV 3.3.5      | Contacting / interconnecting the single cells by soldering in the high current path is prohibited.   | I    |
| EV 3.3.6      | Each accumulator container must have a prominent indicator, such as an LED, that will illuminate whenever a voltage greater than 30 VDC is present at the vehicle side of the AIRs. Alternatively, an analog voltmeter may be used.  | I    |
| EV 3.3.7      | The accumulator voltage indicator (see EV3.3.6) must be directly controlled by voltage being present at the connectors using hard-wired electronics. (No software control is permitted). Activating the indicator with the control signal which closes the Accumulator Isolation Relays (AIRs) is not sufficient.                    | D023 |
| EV 3.3.8      | The accumulator voltage indicator must always work, e.g. even if the container is removed from the car.  | D023 |
| <b>EV 3.4</b> | <b>Tractive System Accumulator Container – Mechanical Configuration</b>  |      |
| EV 3.4.3      | All accumulator containers must lie within the surface envelope as defined by IC1.5.1  | D021 |
| EV 3.4.8      | Holes in the container are only allowed for the wiring-harness, ventilation, cooling or fasteners. These holes must be sealed according to EV4.5.  | I    |
| EV 3.4.10     | A sticker with an area of at least 750mm <sup>2</sup> and a red or black lightning bolt on yellow background or red lightning bolt on white background must be applied on every accumulator container. The sticker must also contain the text “High Voltage” or something similar if the accumulator voltage is greater than 30 VDC. | I    |
| <b>EV 3.5</b> | <b>Accumulator Isolation Relay(s) (AIR)</b>  |      |
| EV 3.5.1      | At least two isolation relays must be installed in every accumulator container.  | I    |
| EV 3.5.2      | The accumulator isolation relays must open both poles of the accumulator.  | T000 |
| EV 3.5.3      | If these relays are open, no TSV may be present outside of the accumulator container. (Including to the AMS)   | T000 |
| EV 3.5.4      | The isolation relays must be of a “normally open” type.  | I    |
| EV 3.5.5      | The fuse protecting the accumulator circuit must have a rating lower than the voltage and current ratings of the isolation relays.   | D021 |
| EV 3.5.6      | Accumulator isolation relays containing mercury are not permitted.   | I    |
| <b>EV 3.6</b> | <b>Accumulator Management System (AMS)</b>   |      |
| EV 3.6.1      | Each accumulator must be monitored by an accumulator management system whenever the tractive system is active or the accumulator is connected to a charger.  | I    |

|          |  |               |
|----------|--|---------------|
| EV 3.6.2 | The AMS must continuously measure cell voltages in order to keep those voltages inside the allowed minimum and maximums stated in the cell data sheet. If single cells are directly connected in parallel, only one voltage measurement is needed. (See Table 11)  | T000          |
| EV 3.6.3 | The AMS must continuously measure the temperatures of critical points of the accumulator to keep the cells below the allowed maximum cell temperature bound stated in the cell data sheet.   | D021          |
| EV 3.6.4 | All voltage sense wires to the AMS must be either protected by fuses as defined in ARTICLE EV6 or must be protected by resistors so that they cannot exceed their current carrying capacity in the event of a short circuit. Any fuse or resistor must be located as close as possible to the energy source. If any of these fuses are blown or if the connection to measure the cell voltage is interrupted in any other way then this must be detected by the AMS and must be reported as a critical voltage problem. If the AMS monitoring board is directly connected to the cell, it is acceptable to have a fuse integrated into the monitoring board.   | D024          |
| EV 3.6.5 | Any GLV connection to the AMS must be galvanically isolated from the TSV, including any connections to external devices such as laptops. This isolation must be documented in the ESF.   | D021, T000    |
| EV 3.6.6 | The AMS must monitor the temperature of the minimum number of cells in the accumulator as specified in Table 12 below. The monitored cells must be equally distributed over the accumulator container(s).  | T000, I       |
| EV 3.6.7 | The AMS must shut down the tractive system by opening the AIRs if critical voltage or temperature values are detected. The tractive system must remain disabled until manually reset by a person other than the driver. It must not be possible for the driver to re-activate the tractive system from within the car in case of an AMS fault.   | T001          |
| EV 3.6.8 | Team-Designed Accumulator Management Systems: Teams may design and build their own Accumulator Management Systems. However, microprocessor-based accumulator management systems are subject to the following restrictions: (a) The processor must be dedicated to the AMS function only. However it may communicate with other systems through shared peripherals or other physical links. (b) The AMS circuit board must include a watchdog time (Maxim MAX6373 or similar) which is physically separate from the CPI. (c) The external watchdog time must be hardwired to the AIRs through an electro-mechanical relay such that a watchdog timeout or lost of power to the circuit board will result in the AIRs opening (d) The watchdog “tickle” input must be driven high and low in separate routines (i.e. no “compliment port pin” code) At least one watchdog input transition must be driven inside a foreground routine, i.e. both transitions may not be contained in timer or externally-triggered interrupt routines. (e) The code that drives the watchdog input may not be located such that a malfunction resulting in continuous internal watchdog timeouts could prevent the external watchdog timer from timing out. (f) The external watchdog time must be demonstrable. | I, T000, D021 |

|               |  |      |
|---------------|--|------|
| <b>EV 4.1</b> | <b>Separation of Traction System and Grounded Low Voltage System</b>   |      |
| EV 4.1.3      | Traction system and GLV circuits must be physically segregated. I.e. they may not run through the same conduit or connector, except for interlock circuit connections.   | D021 |
| EV 4.1.4      | GLV circuits must not be present in the accumulator container except for required purposes, for example the AMS and AIR. This must be demonstrated in the ESF submission.  | D021 |
| EV 4.1.5      | Where both tractive system circuits and GLV circuits are present within an enclosure, they must be (a) separated by electrical insulating barriers rated for 150 C or higher (e.g. Nomex based electrical insulation), or (b) separated by the spacings shown in Table 13 through air, or over a surface (similar to those defined in UL1741):   | D021 |
| EV 4.1.6      | Spacing must be clearly defined. Components and cables capable of movement must be positively restrained to maintain spacing.  | I    |
| EV 4.1.7      | If tractive system circuits and GLV circuits are on the same circuit board they must be on separate, clearly defined areas of the board. Furthermore, the tractive system and GLV areas must be clearly marked on the PCB.   | I    |
| EV 4.1.8      | Teams must be prepared to demonstrate spacings on team-built equipment. Information on this must be included in the ESF (EV9.1). For inaccessible circuitry, spare boards or appropriate photographs must be available for inspection.   | I    |
| <b>EV 4.2</b> | <b>Positioning of Tractive System Parts</b>  |      |
| EV 4.2.5      | There must be a layer of an electrically insulating material between any tractive terminal or connection and the firewall or frame if they are within 50 mm (2 inches) of one another.   | I    |
| <b>EV 4.5</b> | <b>TSV Insulation, Wiring, and Conduit</b>   |      |
| EV 4.5.1      | All parts especially live wires, contacts, etc. of the tractive system need to be isolated by non-conductive material or covers to be protected from being touched. In order to achieve this, it must not be possible to touch any tractive system connections with a 10 cm long, 0.6 cm diameter insulated test probe when the tractive system enclosures are in place.                     | I    |
| EV 4.5.2      | Non-conductive covers must prevent inadvertent human contact with any tractive system circuit. This must include crew members working on or inside the vehicle. Covers must be secure and adequately rigid. Body panels that must be removed to access other components, etc. are not a substitute for enclosing tractive system connections.  | I    |
| EV 4.5.5      | All electrical insulating material must be appropriate for the application in which it is used.  | D022 |
| EV 4.5.6      | All wires and terminals and other conductors used in the tractive system must be sized appropriately for the continuous rating of the fuse which protects them. Wires must be marked with wire gauge, temperature rating and insulation voltage rating. Alternatively a manufacturers part number printed on the wire is sufficient if this can be referenced to a manufacturers data sheet. | I    |

|               |   |      |
|---------------|---|------|
|               | The minimum acceptable temperature rating for TSV cables is 90°C.   |      |
| EV 4.5.7      | All tractive system wiring must be done to professional standards with appropriately sized conductors and terminals and with adequate strain relief and protection from loosening due to vibration etc. Conductors and terminals cannot be modified from their original size/shape and must be appropriate for the connection being made.                                 | I    |
| EV 4.5.11     | All tractive system connections must be designed so that they use intentional current paths through conductors such as copper or aluminum and should not rely on steel bolts to be the primary conductor. The connections must not include compressible material such as plastic in the stack-up.   | D023 |
| EV 4.5.13     | If external, un-insulated heat sinks are used, they must be properly grounded to the GLV system ground  | I    |
| <b>EV 4.6</b> | <b>Tractive System Enclosures</b>   |      |
| EV 4.6.1      | Every housing or enclosure containing parts of the tractive system except motor housings must be labeled with (a) reasonably sized sticker(s) with a red or black lightning bolt on yellow background or red lightning bolt on white background. The sticker must also contain the text "High Voltage" or something similar if the voltage is more than 30 VDC or 25 VAC. | I    |
| <b>EV 4.7</b> | <b>High Voltage Disconnect(HVD)</b>   |      |
| EV 4.7.1      | It must be possible to disconnect at least one pole of the tractive system accumulator by quickly removing an accessible element, fuse or connector.  | T001 |
| EV 4.7.3      | The team must demonstrate this during Electrical Tech Inspection. Being able to quickly disconnect the accumulator(s) from the rest of the tractive system by its connector(s) will satisfy this rule.  | T001 |
| EV 4.7.4      | The Disconnect must be clearly marked with "HVD".   | I    |
| EV 4.7.5      | If a tool is needed to open the HVD this tool must be attached to the push bar.   | I    |
| EV 4.7.6      | If no tools are needed to open the HVD, an interlock must open up the shutdown circuit when the HVD is removed.   | I    |
| <b>EV 5.1</b> | <b>Shutdown Circuit</b>   |      |
| EV 5.1.1      | The shutdown circuit must directly carry the current driving the accumulator isolation relays (AIRs).   | D023 |
| EV 5.1.2      | The shutdown circuit consists of at least 2 master switches, 3 shut-down buttons, the brake-over- travel-switch, the insulation monitoring device (IMD), all required interlocks and the accumulator management system (AMS).   | I    |
| EV 5.1.3      | If the shutdown circuit is opened/interrupted the tractive system must be shut down by opening all accumulator isolation relay(s) and the voltage in the tractive system must drop to under 30 VDC or 25 VAC RMS in less than five seconds after opening the shutdown circuit.  | T000 |
| EV 5.1.5      | It must not be possible for the driver to re-activate the tractive system from within the car in case of an AMS or IMD fault.   | T000 |

|               |   |      |
|---------------|---|------|
| <b>EV 6.1</b> | <b>Fusing</b>   |      |
| EV 6.1.1      | All electrical systems (both tractive system and grounded low voltage system) must be appropriately fused.  | D024 |
| EV 6.1.2      | The continuous current rating of a fuse must not be greater than the continuous current rating of any electrical component, for example wire, busbar, battery cell or other conductor that it protects.   | D024 |
| EV 6.1.3      | All fuses and fuse holders must be rated for the highest voltage in the systems they protect. Fuses used for DC must be rated for DC, and must carry a DC rating equal to or greater than the system voltage of the system in which they are used.  | D024 |
| EV 6.1.4      | All fuses must have an interrupt current rating which is higher than the theoretical short circuit current of the system that it protects.  | D024 |
| <b>EV 8.2</b> | <b>Charging</b>   |      |
| EV 8.2.3      | It is also possible to charge the accumulators outside the car with a removable accumulator container.  | T002 |
| EV 8.2.4      | The accumulator containers or the car itself, depending on whether the accumulators are charged externally or internally, must have a label with the following data during charging: Team name and Safety Responsible phone number(s).  | I    |
| EV 8.2.5      | Only chargers presented and sealed at Electrical Tech Inspection are allowed. All connections of the charger(s) must be isolated and covered. No open connections are allowed.  | I    |
| EV 8.2.10     | High Voltage wiring in an off board charger does not require conduit; however it must be a UL listed flexible cable that complies with NEC Article 400; double insulated.   | I    |
| EV 8.2.11     | All chargers must be UL (Underwriters Laboratories) listed. Any waivers of this requirement require approval in advance, based on documentation of the safe design and construction of the system, including galvanic isolation between the input and output of the charger. Waivers for chargers must be submitted at least 30 days prior to the start of the competition. | I    |

## Appendix B – Analysis Requirements

The table below lists the analysis documents that will be delivered with the ATR as well as the criteria that each document must present in order to be considered complete.

| Document    | Description   | P/F | Date |
|-------------|---|-----|------|
| <b>D011</b> | <b>Measurement Calibration and Accuracy Memo</b>  |     |      |
| R004-5      | Measurand Calibration and Accuracy - The AMS design must be analyzed by a Calibration and Error Analysis document (D011) that states the uncertainties associated with all AMS measurands   |     |      |
| <b>D014</b> | <b>EMI/EMC Analysis Memo</b>  |     |      |
| GPR003      | All designs being considered for production will undergo research to determine if any components or the completed system will breach the EMI/EMC limit as specified in US CFR Title 47 Part 15 subpart B regulations for Class A digital equipment. If infractions are found, an alternative design in compliance with this requirement will be proposed before proceeding with production  |     |      |
| <b>D015</b> | <b>Hazmat Analysis Memo</b>   |     |      |
| GPR004      | System designs will be analyzed for the inclusion of hazardous material before production or procurement of the hazardous substances being used. If a design includes a hazardous material and no alternative design solution is feasible, the Safety officer will update the team's safety plan and system User Manual to include specific instructions for handling these materials both in the lab and in the integrated system. |     |      |
| <b>D016</b> | <b>LFEV-Y2-2014 Safety Plan</b>   |     |      |
| GPR005      | Safety and Good Practice  |     |      |
| <b>D017</b> | <b>Reliability Report</b>   |     |      |
| GPR006      | Reliability - During subsystem design, all components involved will undergo testing and/or research to determine an accurate MTBF and therefore obtain an overall MTBF for the whole system. This report will be included on the website and in the set of deliverables for CDR and final system submission.  |     |      |
| <b>D018</b> | <b>Maintainability Report</b>   |     |      |
| GPR006      | Maintainability - Subsystem designs will be completed with the maintainability procedures in mind. A full maintenance manual for the system and MTTR reports will be submitted with the fully integrated system and to the website for reference purposes.  |     |      |
| R001-6      | A backup system or recovery strategy must be developed to all the VSCADA system to be promptly repaired after a hardware failure in less time than the MTTR given in GPR007   |     |      |
| R002-6      | Software written shall be maintainable as specified in GPR007   |     |      |
| <b>D019</b> | <b>System Bill of Materials</b>   |     |      |
| GPR008      | Manufacturability - A BOM will be provided for each subsystem at CDR. Analysis of parts on the BOM will ensure they meet tolerance standards as outlined and are available from at least two  |     |      |

|             |  |  |  |
|-------------|--|--|--|
|             | manufacturers.   |  |  |
| <b>D020</b> | <b>LFEV-Y1-2013 Subsystem Compliance Memo</b>  |  |  |
| R003-1      | Parts of the 2013 project that do adequately meet LFEV requirements may not be discarded and replaced with new parts that do not meet those requirements   |  |  |
| <b>D021</b> | <b>Accumulator Container FEV Compliance Memo</b>   |  |  |
| R004-6      | Cooling - The AMS requires a simple, small, manufacturable heat sink cooling system for the bypass switch. Performance of cooling system shall be proved by computer modeling and empirical measurements   |  |  |
| EV 3.2.3    | If the accumulator container(s) is not easily accessible during Electrical Tech Inspection, detailed pictures of the internals taken during assembly must be provided. If the pictures do not adequately depict the accumulator, it may be necessary to disassemble the accumulator to pass Electrical Tech Inspection.  |  |  |
| EV 3.3.3    | All batteries or capacitors that make up the accumulator must be divided into accumulator segments. Maintenance plugs, additional contactors or similar measures must be taken to allow electrical separation of the internal accumulator segments such that the separated segments contain a maximum voltage of less than 120 VDC fully charged and a maximum energy as specified in Table. This separation method must be used whenever the accumulator containers are opened for maintenance and whenever accumulator segments are removed from the container. Maintenance separation requiring tools to isolate the segments will not be accepted.   |  |  |
| EV 3.4.3    | All accumulator containers must lie within the surface envelope as defined by IC1.5.1  |  |  |
| EV 3.5.5    | The fuse protecting the accumulator circuit must have a rating lower than the voltage and current ratings of the isolation relays.   |  |  |
| EV 3.6.8    | Team-Designed Accumulator Management Systems: Teams may design and build their own Accumulator Management Systems. However, microprocessor-based accumulator management systems are subject to the following restrictions: (a) The processor must be dedicated to the AMS function only. However it may communicate with other systems through shared peripherals or other physical links. (b) The AMS circuit board must include a watchdog time (Maxim MAX6373 or similar) which is physically separate from the CPI. (c) The external watchdog time must be hardwired to the AIRs through an electro-mechanical relay such that a watchdog timeout or lost of power to the circuit board will result in the AIRs opening (d) The watchdog "tickle" input must be driven high and low in separate routines (i.e. no "compliment port pin" code) At least one watchdog input transition must be driven inside a foreground routine, i.e. both transitions may not be contained in timer or externally-triggered interrupt routines. (e) The code that drives the watchdog input may not be located such that a malfunction resulting in continuous internal watchdog timeouts could prevent the external watchdog timer from timing out. (f) The external watchdog time must be demonstrable. |  |  |
| <b>D022</b> | <b>GLV/HV Isolation FEV Compliance Memo</b>  |  |  |



|             |  |  |  |
|-------------|--|--|--|
| EV 3.6.5    | Any GLV connection to the AMS must be galvanically isolated from the TSV, including any connections to external devices such as laptops. This isolation must be documented in the ESF.   |  |  |
| EV 4.1.3    | Traction system and GLV circuits must be physically segregated. I.e. they may not run through the same conduit or connector, except for interlock circuit connections.   |  |  |
| EV 4.1.4    | GLV circuits must not be present in the accumulator container except for required purposes, for example the AMS and AIR. This must be demonstrated in the ESF submission.  |  |  |
| EV 4.1.5    | Where both tractive system circuits and GLV circuits are present within an enclosure, they must be (a) separated by electrical insulating barriers rated for 150 C or higher (e.g. Nomex based electrical insulation), or (b) separated by the spacings shown in Table 13 through air, or over a surface (similar to those defined in UL1741):   |  |  |
| EV 4.5.5    | All electrical insulating material must be appropriate for the application in which it is used.  |  |  |
| <b>D023</b> | <b>TSV/AIR FEV Compliance Memo</b>   |  |  |
| EV 3.3.7    | The accumulator voltage indicator (see EV3.3.6) must be directly controlled by voltage being present at the connectors using hard-wired electronics. (No software control is permitted). Activating the indicator with the control signal which closes the Accumulator Isolation Relays (AIRs) is not sufficient.  |  |  |
| EV 4.5.11   | All tractive system connections must be designed so that they use intentional current paths through conductors such as copper or aluminum and should not rely on steel bolts to be the primary conductor. The connections must not include compressible material such as plastic in the stack-up.  |  |  |
| EV 4.9.2    | It is allowed to pre-charge the intermediate circuit for a conservatively calculated time before closing the second AIR. A feedback via measuring the current intermediate circuit voltage is not required.  |  |  |
| EV 5.1.1    | The shutdown circuit must directly carry the current driving the accumulator isolation relays (AIRs).  |  |  |
| <b>D024</b> | <b>Fusing FEV Compliance Memo</b>  |  |  |
| EV 3.6.4    | All voltage sense wires to the AMS must be either protected by fuses as defined in ARTICLE EV6 or must be protected by resistors so that they cannot exceed their current carrying capacity in the event of a short circuit. Any fuse or resistor must be located as close as possible to the energy source. If any of these fuses are blown or if the connection to measure the cell voltage is interrupted in any other way then this must be detected by the AMS and must be reported as a critical voltage problem. If the AMS monitoring board is directly connected to the cell, it is acceptable to have a fuse integrated into the monitoring board. |  |  |
| EV 6.1.1    | All electrical systems (both tractive system and grounded low voltage system) must be appropriately fused.   |  |  |
| EV 6.1.2    | The continuous current rating of a fuse must not be greater than the continuous current rating of any electrical component, for example wire, busbar, battery cell or other conductor that it protects.  |  |  |



---

|          |  |  |  |
|----------|--|--|--|
| EV 6.1.3 | All fuses and fuse holders must be rated for the highest voltage in the systems they protect. Fuses used for DC must be rated for DC, and must carry a DC rating equal to or greater than the system voltage of the system in which they are used. |  |  |
| EV 6.1.4 | All fuses must have an interrupt current rating which is higher than the theoretical short circuit current of the system that it protects.   |  |  |

## Appendix C – Inspection Guide

This guide lists all the system requirements that will be met by inspection.

| Requirement | Description  | P/F | Date |
|-------------|--|-----|------|
| <b>R000</b> | <b>Formula Hybrid Competition Rules</b>  |     |      |
| R000        | The Formula Hybrid Competition rule sections relating to electrical and power subsystems of the completed car will be analyzed to determine what rules are applicable to the scope of the proposed design. All rules determined to be within the proposed scope will become constraints and requirements within the design of the integrated system in order to produce a competition ready and compliant product at the completion of the project |     |      |
| <b>R001</b> | <b>VSCADA</b>  |     |      |
| R001-8      | All VSCADA application software must be written in conformance with a documented API using a delivered SDK   |     |      |
| <b>R002</b> | <b>VSCADA API, SDK, and Applications</b>   |     |      |
| R002-1      | Scope of the API must be sufficient to support both low level debugging applications and high-level automated applications on all hardware platforms in use. Same API must be used for all applications running on or off-car  |     |      |
| R002-2      | SDK must include a complete tool chain with compilers, linkers, libraries, include files, utilities, and developer level documentation. All tools shall be actively supported and mature   |     |      |
| R002-3      | All sources must be maintained under configuration control   |     |      |
| R002-4      | The complete SDK, including API and application source under configuration control shall be delivered to or linked by the project website  |     |      |
| R002-5      | API, SDK, and applications shall be copyrighted using open source practices. The team shall identify and GPL all software written by the team  |     |      |
| <b>R003</b> | <b>Use of the 2013 Design</b>  |     |      |
| R003-2      | The pack design must not be altered significantly, except for AMS improvement required by R004   |     |      |
| <b>R005</b> | <b>MCS and Test Stand Requirements</b>   |     |      |
| R005-1      | Motor and Controller system shall be provided to meet the requirements of the IEEE FEV competition and should be sized suitably to achieve a reasonably competitive entry  |     |      |
| R005-2      | An MCS test stand shall be provided to permit the safe testing and demonstration of motor and controller performance over the operation parameters(RPM and torque profiles) implied by the IEEE FEV competition  |     |      |
| R005-3      | The MCS test stand shall be instrumented with sensors that are interfaced to the VSCADA, reporting relevant performance parameters measured at the Test Stand  |     |      |

|               |  |  |  |
|---------------|--|--|--|
| <b>R006</b>   | <b>Battery Pack Requirements</b>   |  |  |
| R006-1        | Voltage - The system design requires a 7-cell pack, with nominal voltage of 24 VDC. The 3-cell pack design from 2013 should be extended to 7 cells   |  |  |
| R006-3        | Charger Interface - The charging interface shall be reliable, maintainable, and contain safety features that meet requirements. This includes an improved fusing of the charger path from the 2013 design  |  |  |
| <b>GPR</b>    | <b>General Project Requirements</b>  |  |  |
| GPR001        | Documentation - Block Diagrams and schematics for all subsystems being designed will be completed using computer aided drawing programs and will be posted upon completion. Two members of the team have been designated as "Editors" and will review submitted technical memos, manuals, and drawings for accuracy, professionalism, and formatting.  |  |  |
| GPR011        | Project Demonstration - Upon complete system integration, QA, and fulfillment of the Acceptance Test Plan, a live demonstration will be presented to the ECE faculty and students. The completed battery pack and related systems will be self contained and able to operate for at least 50 days without the need of being charged, thus becoming a maintenance free display for ECE visitors.  |  |  |
| GPR012        | Final disposal of project will take place the week of May 5th. System should be completed and demonstrated by this date, so final disposal is the final step to completion of the project. If adequate room is available, the battery pack can be displayed in the ECE hallway for visitors. Charger, MCS and test stand, and left over materials will be stored in AEC 402 or 400 in an orderly and inventoried fashion. All trash or disorder in AEC 400 which was a result of this project will be disposed over. |  |  |
| <b>EV 1.2</b> | <b>Grounded Low Voltage and Tractive System Voltage</b>  |  |  |
| EV 1.2.6      | The tractive system motor(s) must be connected to the accumulator through a motor controller. Bypassing the control system and connecting the tractive system accumulator directly to the motor(s) is prohibited.  |  |  |
| EV 1.3.1      | All Electrical insulating materials used must: (a) Be UL recognized (i.e, have an Underwriters Laboratories ( <a href="http://www.UL.com">www.UL.com</a> ) or equivalent rating and certification). (b) be rated for the maximum expected operating temperatures at the location of use or (c) have a minimum temperature rating of 90C. (Whichever is greater)  |  |  |
| EV 1.3.2      | Vinyl electrical insulating tape and rubber-like paints and coatings are not acceptable electrical insulating materials.   |  |  |
| <b>EV 3.1</b> | <b>Allowed Tractive Systems</b>  |  |  |
| EV 3.1.1      | The following accumulators are acceptable; batteries (e.g. lithium-ion batteries, NiMH batteries, lead acid batteries and many other rechargeable battery chemistries) and capacitors, such as super caps or ultra caps. The following accumulators are not permitted; molten salt batteries, thermal batteries, fuel cell, atomic and flywheel mechanical batteries.  |  |  |
| EV 3.1.2      | Manufacturer's data sheets showing the rated specification of the accumulator cell(s) which are used must be provided in the ESF   |  |  |

|               |   |  |  |
|---------------|---|--|--|
|               | along with their number and configurations.   |  |  |
| <b>EV 3.2</b> | <b>Tractive System Accumulator Container – General Requirements</b>   |  |  |
| EV 3.2.1      | All batteries or capacitors which store the tractive system energy must be enclosed in (an) accumulator containers  |  |  |
| EV 3.2.2      | If spare accumulators are to be used then they all must be of the same size, weight and type as those that are replaced. Spare accumulator packs must be presented at Electrical Tech Inspection.   |  |  |
| <b>EV 3.3</b> | <b>Tractive System Accumulator Container</b>  |  |  |
| EV 3.3.1      | If the container is made of electrically conductive material, the poles of the accumulator stack(s) and/or cells must be electrically insulated from the inside wall of the accumulator container by insulating material rated for the maximum voltage of the tractive system. All conductive surfaces on the outside of the container must have a low-resistance connection to the GLV system ground. All conductive penetrations (mounting hardware, etc.) must be located outside of the insulation and configured such that there is no possibility that they could penetrate the insulating barrier. |  |  |
| EV 3.3.2      | Every accumulator container must contain at least one fuse  |  |  |
| EV 3.3.5      | Contacting / interconnecting the single cells by soldering in the high current path is prohibited.  |  |  |
| EV 3.3.7      | The accumulator voltage indicator (see EV3.3.6) must be directly controlled by voltage being present at the connectors using hard-wired electronics. (No software control is permitted). Activating the indicator with the control signal which closes the Accumulator Isolation Relays (AIRs) is not sufficient.   |  |  |
| <b>EV 3.4</b> | <b>Tractive System Accumulator Container – Mechanical Configuration</b>   |  |  |
| EV 3.4.8      | Holes in the container are only allowed for the wiring-harness, ventilation, cooling or fasteners. These holes must be sealed according to EV4.5.   |  |  |
| EV 3.4.10     | A sticker with an area of at least 750mm <sup>2</sup> and a red or black lightning bolt on yellow background or red lightning bolt on white background must be applied on every accumulator container. The sticker must also contain the text “High Voltage” or something similar if the accumulator voltage is greater than 30 VDC.  |  |  |
| <b>EV 3.5</b> | <b>Accumulator Isolation Relay(s) (AIR)</b>   |  |  |
| EV 3.5.1      | At least two isolation relays must be installed in every accumulator container.   |  |  |
| EV 3.5.4      | The isolation relays must be of a “normally open” type.   |  |  |
| EV 3.5.6      | Accumulator isolation relays containing mercury are not permitted.  |  |  |
| <b>EV 3.6</b> | <b>Accumulator Management System (AMS)</b>  |  |  |
| EV 3.6.1      | Each accumulator must be monitored by an accumulator management system whenever the tractive system is active or the accumulator is connected to a charger.   |  |  |
| EV 3.6.6      | The AMS must monitor the temperature of the minimum number of cells in the accumulator as specified in Table 12 below. The monitored cells must be equally distributed over the accumulator container(s).   |  |  |

|               |   |  |  |
|---------------|---|--|--|
| EV 3.6.8      | <p>Team-Designed Accumulator Management Systems: Teams may design and build their own Accumulator Management Systems. However, microprocessor-based accumulator management systems are subject to the following restrictions: (a) The processor must be dedicated to the AMS function only. However it may communicate with other systems through shared peripherals or other physical links. (b) The AMS circuit board must include a watchdog time (Maxim MAX6373 or similar) which is physically separate from the CPI. (c) The external watchdog time must be hardwired to the AIRs through an electro-mechanical relay such that a watchdog timeout or lost of power to the circuit board will result in the AIRs opening (d) The watchdog “tickle” input must be driven high and low in separate routines (i.e. no “compliment port pin” code) At least one watchdog input transition must be driven inside a foreground routine, i.e. both transitions may not be contained in timer or externally-triggered interrupt routines. (e) The code that drives the watchdog input may not be located such that a malfunction resulting in continuous internal watchdog timeouts could prevent the external watchdog timer from timing out. (f) The external watchdog time must be demonstrable.</p> |  |  |
| <b>EV 4.1</b> | <b>Separation of Traction System and Grounded Low Voltage System</b>  |  |  |
| EV 4.1.6      | Spacing must be clearly defined. Components and cables capable of movement must be positively restrained to maintain spacing.   |  |  |
| EV 4.1.7      | If tractive system circuits and GLV circuits are on the same circuit board they must be on separate, clearly defined areas of the board. Furthermore, the tractive system and GLV areas must be clearly marked on the PCB.  |  |  |
| EV 4.1.8      | Teams must be prepared to demonstrate spacings on team-built equipment. Information on this must be included in the ESF (EV9.1). For inaccessible circuitry, spare boards or appropriate photographs must be available for inspection.  |  |  |
| <b>EV 4.2</b> | <b>Positioning of Tractive System Parts</b>   |  |  |
| EV 4.2.5      | There must be a layer of an electrically insulating material between any tractive terminal or connection and the firewall or frame if they are within 50 mm (2 inches) of one another.  |  |  |
| <b>EV 4.5</b> | <b>TSV Insulation, Wiring, and Conduit</b>  |  |  |
| EV 4.5.1      | All parts especially live wires, contacts, etc. of the tractive system need to be isolated by non- conductive material or covers to be protected from being touched. In order to achieve this, it must not be possible to touch any tractive system connections with a 10 cm long, 0.6 cm diameter insulated test probe when the tractive system enclosures are in place.   |  |  |
| EV 4.5.2      | Non-conductive covers must prevent inadvertent human contact with any tractive system circuit. This must include crew members working on or inside the vehicle. Covers must be secure and adequately rigid. Body panels that must be removed to access other components, etc. are not a substitute for enclosing tractive system connections.   |  |  |
| EV 4.5.6      | All wires and terminals and other conductors used in the tractive   |  |  |

|               |  |  |  |
|---------------|--|--|--|
|               | system must be sized appropriately for the continuous rating of the fuse which protects them. Wires must be marked with wire gauge, temperature rating and insulation voltage rating. Alternatively a manufacturers part number printed on the wire is sufficient if this can be referenced to a manufacturers data sheet. The minimum acceptable temperature rating for TSV cables is 90°C. |  |  |
| EV 4.5.7      | All tractive system wiring must be done to professional standards with appropriately sized conductors and terminals and with adequate strain relief and protection from loosening due to vibration etc. Conductors and terminals cannot be modified from their original size/shape and must be appropriate for the connection being made.  |  |  |
| EV 4.5.13     | If external, un-insulated heat sinks are used, they must be properly grounded to the GLV system ground   |  |  |
| <b>EV 4.6</b> | <b>Tractive System Enclosures</b>  |  |  |
| EV 4.6.1      | Every housing or enclosure containing parts of the tractive system except motor housings must be labeled with (a) reasonably sized sticker(s) with a red or black lightning bolt on yellow background or red lightning bolt on white background. The sticker must also contain the text "High Voltage" or something similar if the voltage is more than 30 VDC or 25 VAC.                    |  |  |
| <b>EV 4.7</b> | <b>High Voltage Disconnect(HVD)</b>  |  |  |
| EV 4.7.4      | The Disconnect must be clearly marked with "HVD".  |  |  |
| EV 4.7.5      | If a tool is needed to open the HVD this tool must be attached to the push bar.  |  |  |
| EV 4.7.6      | If no tools are needed to open the HVD, an interlock must open up the shutdown circuit when the HVD is removed.  |  |  |
| <b>EV 5.1</b> | <b>Shutdown Circuit</b>  |  |  |
| EV 5.1.2      | The shutdown circuit consists of at least 2 master switches, 3 shutdown buttons, the brake-over- travel-switch, the insulation monitoring device (IMD), all required interlocks and the accumulator management system (AMS).   |  |  |
| <b>EV 8.2</b> | <b>Charging</b>  |  |  |
| EV 8.2.4      | The accumulator containers or the car itself, depending on whether the accumulators are charged externally or internally, must have a label with the following data during charging: Team name and Safety Responsible phone number(s).   |  |  |
| EV 8.2.5      | Only chargers presented and sealed at Electrical Tech Inspection are allowed. All connections of the charger(s) must be isolated and covered. No open connections are allowed.   |  |  |
| EV 8.2.10     | High Voltage wiring in an off board charger does not require conduit; however it must be a UL listed flexible cable that complies with NEC Article 400; double insulated.  |  |  |
| EV 8.2.11     | All chargers must be UL (Underwriters Laboratories) listed. Any waivers of this requirement require approval in advance, based on documentation of the safe design and construction of the system, including galvanic isolation between the input and output of the charger. Waivers for chargers must be submitted at least 30 days prior to the start of the competition.                  |  |  |

## Appendix D – Test Results Form

This form is provided in order to quickly see which tests (and thus, which requirements) have been passed.

| Test           | Description  | P/F | Date |
|----------------|--|-----|------|
| <b>T000</b>    | <b>Battery Pack Display and Safety Qualification</b>   |     |      |
| <b>T000.1</b>  | The multimeter measured voltage of the total pack voltage is within $\pm$ _____% of the displayed total voltage on the character LCD screen. |     |      |
| <b>T000.2</b>  | The pack current displayed on the character LCD screen is $< 1A \pm$ _____%  |     |      |
| <b>T000.3</b>  | The pack state of charge (SOC) displayed on the character LCD screen is between 0 and 100 %.   |     |      |
| <b>T000.4</b>  | The measured resistance between the poles of the accumulator container and the inside wall of the pack is $> 1 M\Omega$ .                    |     |      |
| <b>T000.5</b>  | The measured resistance between the discharge path of the pack and GLV components are $> 1M\Omega$ .   |     |      |
| <b>T000.6</b>  | The safety loop is closed when the Safety Loop reset button is pressed.  |     |      |
| <b>T000.7</b>  | The safety loop is opened when the “reset” switch is triggered on the battery pack   |     |      |
| <b>T000.8</b>  | TS-8160-4200’s software begins automatically after the reset switch is triggered and the computer boots itself up again.                     |     |      |
| <b>T000.9</b>  | The safety loop is opened when the TWD 0 command is sent to the pack manager and the watchdog timer times out.                               |     |      |
| <b>T000.10</b> | The Pack Manager returns to normal operation and the safety loop closes when TWD 1 is sent to the pack manager.                              |     |      |
| <b>T000.11</b> | The safety loop is opened when the TOB 1 command is sent to the pack manager to simulate an out of bounds reading.                           |     |      |
| <b>T001</b>    | <b>Low Current Discharge Test</b>  |     |      |
| <b>T001.1</b>  | Connectors cannot be removed without use of tools  |     |      |
| <b>T001.2</b>  | Resistance measurement between the pack’s HV poles is $> 1M\Omega$ when at least one of the AIRs are open.                                   |     |      |
| <b>T001.3</b>  | The safety loop is closed when the “reset safety loop” button is pressed.  |     |      |
| <b>T001.4</b>  | The discharge current displayed on the LCD screen of the   |     |      |

|                |  |  |  |
|----------------|--|--|--|
|                | battery pack is within $\pm$ _____% of the drawn current displayed on the load resistor unit.  |  |  |
| <b>T001.5</b>  | The pack manager's LCD display shows the system is in discharge mode.  |  |  |
| <b>T001.6</b>  | The safety loop is opened by the pack manager when a cell voltage reaches the low voltage threshold.   |  |  |
| <b>T001.7</b>  | The TS-8160-4200's green power LED is still lit when it opens the safety loop to end the discharge cycle.  |  |  |
| <b>T002</b>    | <b>Charge Cycle Test</b>   |  |  |
| <b>T002.1</b>  | Safety Loop is closed before the charging cable is plugged into the battery pack and the "dummy" plug is removed from the charging port.   |  |  |
| <b>T002.2</b>  | Safety Loop is opened when the "dummy" plug is removed from the battery pack and the charging cable is plugged into the battery pack.  |  |  |
| <b>T002.3</b>  | The pack manager enters the charging state when the charging cable is plugged into the battery pack by displaying a status message that the pack is charging on the LCD screen.    |  |  |
| <b>T002.4</b>  | The charging relays are closed automatically by the pack manager to allow the battery to begin charging as shown by the drawn current on the power supply.                         |  |  |
| <b>T002.5</b>  | Safety Loop does not close when the reset safety loop button is pressed during the charging cycle.   |  |  |
| <b>T002.6</b>  | No error messages or system failures related to charging were encountered during the charge cycle.   |  |  |
| <b>T002.7</b>  | The time to complete the charge cycle is within $\pm 0.5$ hours of the estimated time of charge based on beginning SOC reported by the pack manager.                               |  |  |
| <b>T002.8</b>  | The LCD screen on the battery pack display a status message indicating charging has completed successfully.  |  |  |
| <b>T002.9</b>  | The LCD screen displays an SOC of $100 \pm$ _____% when the pack manager indicates the battery pack is fully charged.  |  |  |
| <b>T002.10</b> | The charge relays are opened automatically when the pack manager indicates the battery pack is fully charged.  |  |  |
| <b>T002.11</b> | Safety Loop does not open when the reset safety loop button is pressed after the charging cycle has completed but before the charger cable has been removed from the battery pack. |  |  |
| <b>T002.12</b> | Pack manager enters the discharging state and removes the charging complete status message from the LCD display after the charging cable is disconnected from the battery pack.    |  |  |



|                |  |  |  |
|----------------|--|--|--|
| <b>T002.13</b> | Safety Loop is closed after the charging cable is removed from the battery pack and the “dummy” charge plug is inserted into the charging port.  |  |  |
| <b>T003</b>    | <b>Drop-Out Charge Test</b>  |  |  |
| <b>T003.1</b>  | The TS-8160-4200’s green power LED becomes unlit when the pack voltage is removed from the pack manager.   |  |  |
| <b>T003.2</b>  | The TS-8160-4200’s green power LED becomes lit when the charger is plugged into the battery pack and its output is turned on, and the charge relay override button is held in.   |  |  |
| <b>T003.3</b>  | The pack manager’s software begins automatically and is not corrupted after the charger is plugged into the battery pack, its output is turned on, and the charge relay override button is held in.                              |  |  |
| <b>T003.4</b>  | The character LCD screen displays pack information (SOC, Pack Voltage, Pack Current) within 10 seconds after plugging the charger into the battery pack, turning on its output, and holding in the charge relay override button. |  |  |
| <b>T003.5</b>  | No error messages or system failures relevant to charging were encountered during the charge cycle.  |  |  |
| <b>T003.6</b>  | The LCD screen on the battery pack display a status message indicating charging has completed successfully.  |  |  |
| <b>T003.7</b>  | The LCD screen displays a SOC of $100 \pm \text{_____}$ % when the pack manager indicates the battery pack is fully charged.   |  |  |
| <b>T003.8</b>  | The charging relays are opened by the pack manager when charging completes as indicated by the current draw on the power supply.   |  |  |
| <b>T003.9</b>  | Pack manager enters shows that it enters the discharging state after charging completes.   |  |  |
| <b>T003.10</b> | Safety Loop is closed after the charging cable is removed from the battery pack, the “dummy” plug is inserted into the pack, and the reset safety loop button is pressed.  |  |  |
| <b>T004</b>    | <b>High Current Discharge Test</b>   |  |  |
| <b>T004.1</b>  | The safety loop is closed when the “reset safety loop” button is pressed.  |  |  |
| <b>T004.2</b>  | The discharge current displayed on the LCD screen of the battery pack is within $\pm 5\%$ of the drawn current displayed on the load resistor unit.  |  |  |
| <b>T004.3</b>  | The discharge fuse remains intact and not blown during the entire high current discharge cycle.  |  |  |
| <b>T004.4</b>  | The safety loop is opened by the pack manager when a cell voltage reaches the low voltage threshold  |  |  |
| <b>T005</b>    | <b>RS-485 Communication with Off-Board Systems</b>   |  |  |

|               |  |  |  |
|---------------|--|--|--|
| <b>T005.1</b> | The pack manager's returns the value 0x42 to RealTerm upon sending the command 1 TEST?.  |  |  |
| <b>T005.2</b> | The pack manager returns to RealTerm 7 as the number of cells when the command 1 CELLCNT? is sent.   |  |  |
| <b>T005.3</b> | The pack manager returns to RealTerm 7 voltage measurements when the command 1 V? is sent.   |  |  |
| <b>T005.4</b> | The pack manager does not return any information to RealTerm when it receives a command addressed to a different pack manager board  |  |  |
| <b>T006</b>   | <b>MCS and Test Stand Verification</b>   |  |  |
| <b>T006.1</b> | Testing area and setup are confirmed to be safe for future testing and general operation of rotating machinery as defined by the LFEV-14 Safety Plan.  |  |  |
| <b>T006.2</b> | Motor properly operates without any load attached under a low acceleration signal; demonstrates proper operation of both the motor and controller  |  |  |
| <b>T006.3</b> | Motor spins in a controlled fashion after additional acceleration is applied through the motor controller. Motor remains securely attached to test bench and motor spins at constant RPMs when a constant signal is applied across the entire acceleration signal input range. |  |  |
| <b>T006.4</b> | Motor controller operates properly between its voltage range between 72 and 96 VDC; demonstrated by properly controlling the motor from within the power supply range.   |  |  |
| <b>T006.5</b> | Dynamometer displays correct readings from motor test. As defined by the power graphs from the manufactures website.   |  |  |
| <b>T006.6</b> | Motor stops spinning within 120 seconds when acceleration signal is removed.   |  |  |
| <b>T007</b>   | <b>Reliability Test</b>  |  |  |
| <b>T007.1</b> | Testing area and setup are confirmed to be safe for future testing as defined by the LFEV-14 Safety Plan.  |  |  |
| <b>T007.2</b> | At least two qualified individuals were present at all times and monitored the system over the entire 24 hour test period.   |  |  |
| <b>T007.3</b> | System runs through charging and discharging cycles for 24 hours without any obvious failures.   |  |  |
| <b>T008</b>   | <b>Maintainability Tests</b>   |  |  |
| <b>T008.1</b> | A novice user can replace a blown fuse in the system.  |  |  |
| <b>T008.2</b> | An expert user can solve an unexpected maintenance problem.  |  |  |